

22. Exploded View and Replacement Parts List

22.1 Indoor Unit

22.1.1 CS-TZ20ZKEW CS-TZ25ZKEW CS-TZ35ZKEW CS-TZ42ZKEW CS-TZ50ZKEW CS-RZ25ZKEW CS-RZ35ZKEW CS-RZ50ZKEW

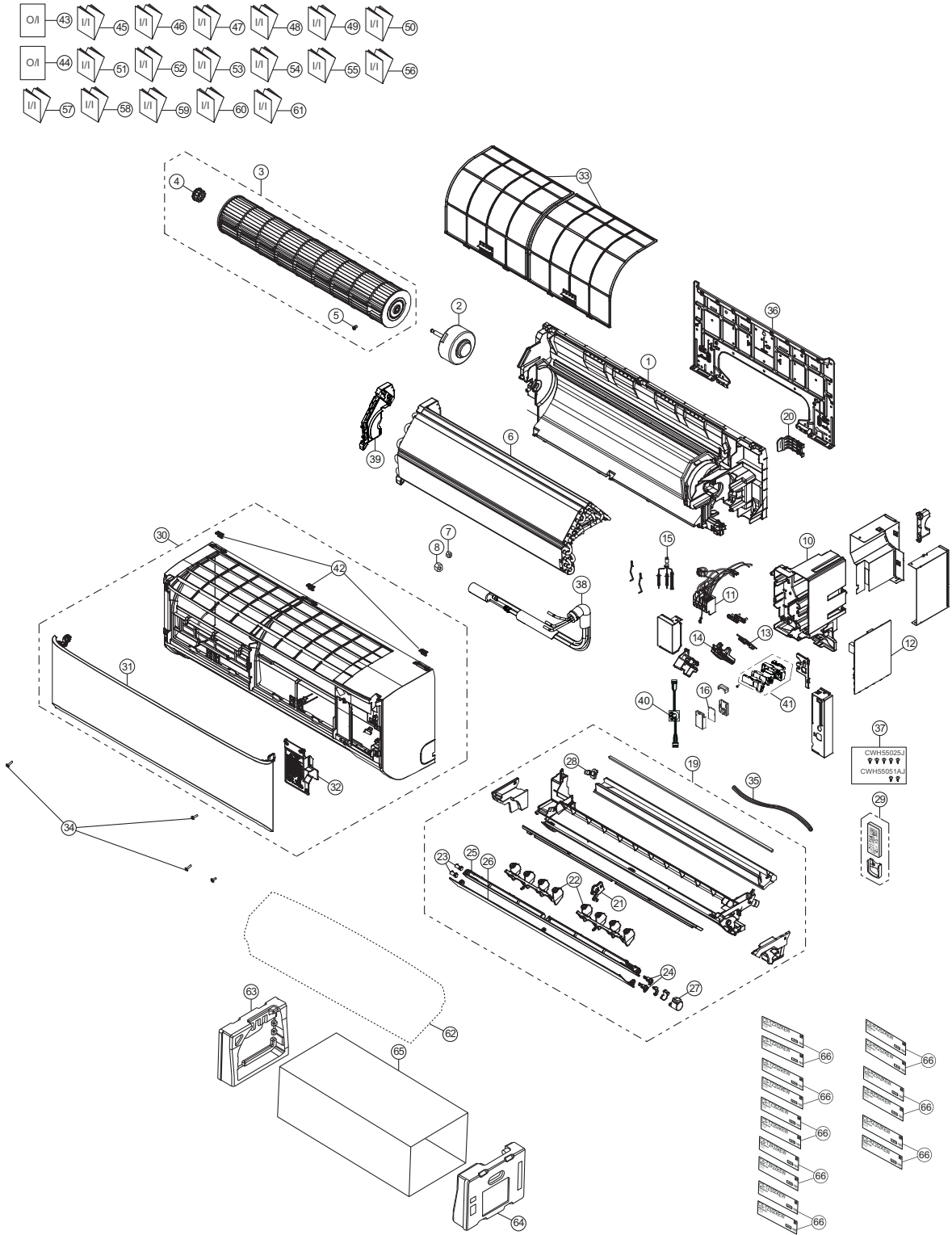

Note
The above exploded view is for the purpose of parts disassembly and replacement.
The non-numbered parts are not kept as standard service parts.

SAFETY	REF. NO.	PART NAME & DESCRIPTION	QTY.	CS-TZ42ZKEW	CS-TZ50ZKEW	REMARK
	1	CHASSIS COMPLETE	1	ACXD50C04620	←	
⚠	2	FAN MOTOR	1	L6CBYYL0311	←	O
	3	CROSS-FLOW FAN COMPLETE	1	ACXH02C01190	←	
	4	BEARING ASSY	1	CWH64K1006	←	
	5	SCREW - CROSS-FLOW FAN	1	CWH551146	←	
	6	EVAPORATOR	1	ACXB30C36720	←	O
	7	FLARE NUT (LIQUID)	1	CWT251063	←	
	8	FLARE NUT (GAS)	1	CWT251032	←	
	10	CONTROL BOARD CASING	1	ACXH10-07900	←	
⚠	11	TERMINAL BOARD COMPLETE	1	ACXA28C05900	ACXA28C05970	O
⚠	12	ELECTRONIC CONTROLLER - MAIN	1	ACXA73C90670	ACXA73C90680	O
⚠	13	ELECTRONIC CONTROLLER-INDICATOR	1	ACXA73-34560	←	O
	14	INDICATOR HOLDER	1	ACXD93-20781	←	
⚠	15	SENSOR COMPLETE	1	CWA50C2664	←	O
⚠	16	ELECTRONIC CONTROLLER-WIFI	1	ACXA73-45970	←	O
	19	DISCHARGE GRILLE COMPLETE	1	ACXE20C08200	←	
	20	BACK COVER CHASSIS	1	ACXD93-18680	←	
	21	FULCRUM	1	ACXH62-00680	←	
	22	VERTICAL VANE	2	ACXE24-03470	←	
	23	SHAFT	2	ACXH63-01540	←	
	24	SHAFT	2	ACXH63-01570	←	
	25	HORIZONTAL VANE - INNER	1	ACXE24-03710	←	
	26	HORIZONTAL VANE - OUTER	1	ACXE24-03720	←	
⚠	27	AIR SWING MOTOR	1	ACXA98-03560	←	O
	28	CAP - DRAIN TRAY	1	CWH521259	←	
⚠	29	REMOTE CONTROL COMPLETE	1	ACXA75C23671	←	O
	30	FRONT GRILLE COMPLETE	1	ACXE10C16850	←	
	31	INTAKE GRILLE ASSY	1	ACXE22C04140	←	
	32	GRILLE DOOR COMPLETE	1	ACXE14C01340	←	
	33	AIR FILTER	2	ACXD00-02860	←	
	34	SCREW - FRONT GRILLE	4	XTT4+16CFJ	←	
	35	DRAIN HOSE	1	ACXH85-00201	←	
	36	INSTALLATION PLATE	1	ACXH36-00650	←	
	37	BAG COMPLETE - INSTALLATION SCREW	1	CWH82C1705	←	
	38	TUBE ASSY-COMPLETE	1	ACXT00C43120	←	
	39	BOX SHAPED PLATE	1	ACXD66-02910	←	
⚠	40	LEAD WIRE-COMPLETE -WIFI	1	ACXA60C96480	←	O
⚠	41	GENERATOR COMPLETE	1	ACXH94C01590	←	O
	42	PARTICULAR PLATE -LOCK	3	ACXD93-18690	←	
	43	OPERATING INSTRUCTION	1	ACXF55-33990	←	
	44	OPERATING INSTRUCTION	1	ACXF55-34000	←	
	45	INSTALLATION INSTRUCTION	1	ACXF60-47630	←	
	46	INSTALLATION INSTRUCTION	1	ACXF60-47640	←	
	47	INSTALLATION INSTRUCTION	1	ACXF60-47650	←	
	48	INSTALLATION INSTRUCTION	1	ACXF60-47660	←	
	49	INSTALLATION INSTRUCTION	1	ACXF60-47670	←	
	50	INSTALLATION INSTRUCTION	1	ACXF60-47680	←	

SAFETY	REF. NO.	PART NAME & DESCRIPTION	QTY.	CS-TZ42ZKEW	CS-TZ50ZKEW	REMARK
	51	INSTALLATION INSTRUCTION	1	ACXF60-47690	←	
	52	INSTALLATION INSTRUCTION	1	ACXF60-47700	←	
	53	INSTALLATION INSTRUCTION	1	ACXF60-47710	←	
	54	INSTALLATION INSTRUCTION	1	ACXF60-47720	←	
	55	INSTALLATION INSTRUCTION	1	ACXF60-47730	←	
	56	INSTALLATION INSTRUCTION	1	ACXF60-49200	←	
	57	INSTALLATION INSTRUCTION	1	ACXF60-49210	←	
	58	INSTALLATION INSTRUCTION	1	ACXF60-49220	←	
	59	INSTALLATION INSTRUCTION	1	ACXF60-49230	←	
	60	INSTALLATION INSTRUCTION	1	ACXF60-49240	←	
	61	INSTALLATION INSTRUCTION	1	ACXF60-49250	←	
	62	BAG	1	ACXG86-00190	←	
	63	SHOCK ABSORBER (LEFT)	1	ACXG70-11650	←	
	64	SHOCK ABSORBER (RIGHT)	1	ACXG70-11660	←	
	65	C.C.CASE	1	ACXG50-54752	←	
	66	MODEL LABEL	2	ACXF87-00680	ACXF87-00690	

(NOTE)

- All parts are supplied from PAPAMY, Malaysia (Vendor Code: 00029488).
- "O" marked parts are recommended to be kept in stock.