

22.1.2 CS-TZ60ZKEW CS-TZ71ZKEW

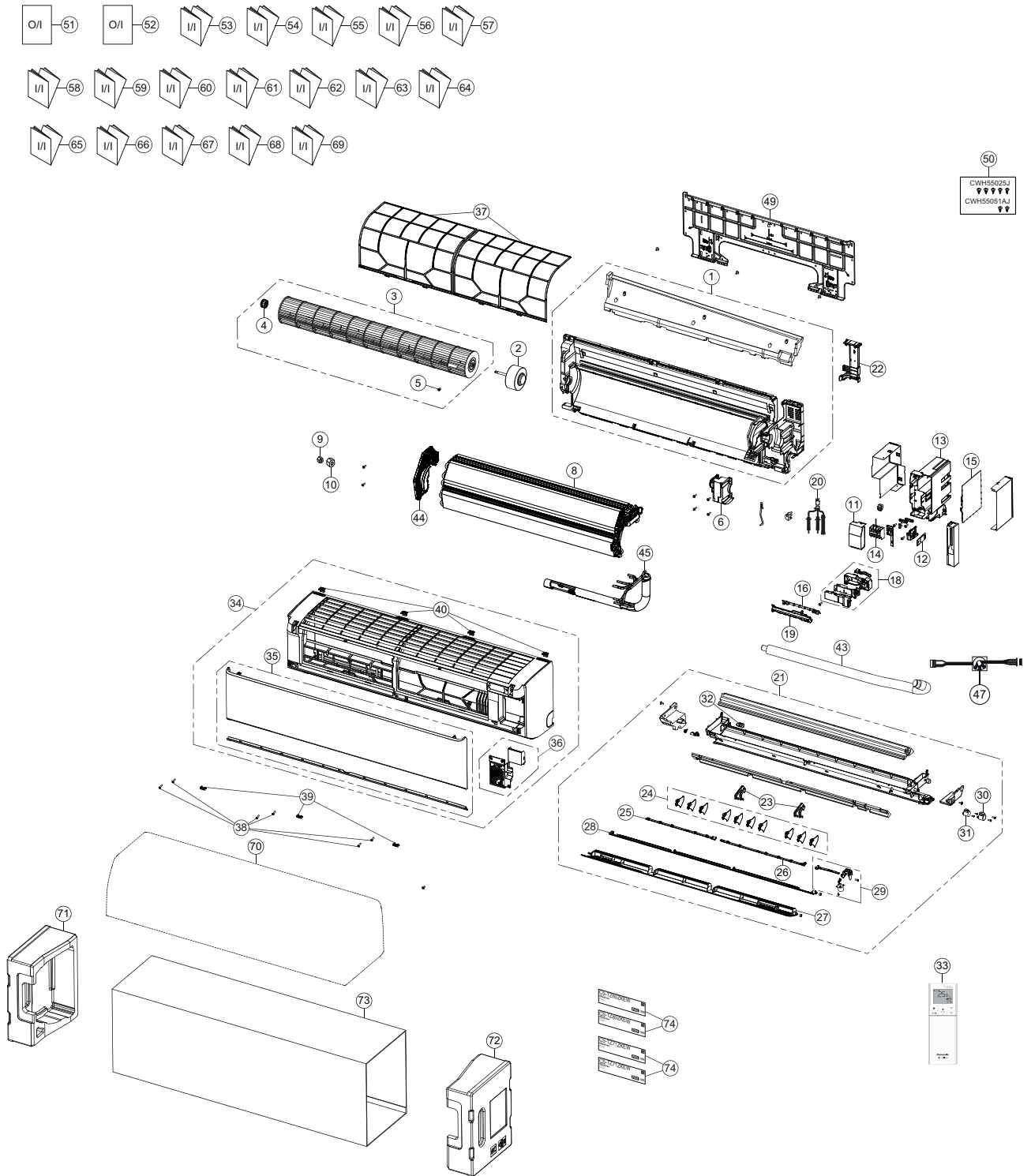

Note

The above exploded view is for the purpose of parts disassembly and replacement.
The non-numbered parts are not kept as standard service parts.

SAFETY	REF. NO.	PART NAME & DESCRIPTION	QTY.	CS-TZ60ZKEW	CS-TZ71ZKEW	REMARK
	1	CHASSIS COMPLETE	1	ACXD50C04180	←	
⚠	2	FAN MOTOR	1	L6CBYYYYL0376	←	O
	3	CROSS-FLOW FAN COMPLETE	1	ACXH02C01450	←	
	4	BEARING ASSY	1	CWH64K1006	←	
	5	SCREW - CROSS-FLOW FAN	1	CWH551146	←	
	6	FAN MOTOR BRACKET	1	ACXD54-04360	←	
	8	EVAPORATOR	1	ACXB30C33300	ACXB30C35590	O
	9	FLARE NUT (LIQUID)	1	CWT251048	←	
	10	FLARE NUT (GAS)	1	CWT251032	CWT251033	
	11	CONTROL BOARD TOP COVER	1	ACXH13-08680	ACXH13-08680	
⚠	12	ELECTRONIC CONTROLLER-WIFI	1	ACXA73-45970	←	O
	13	CONTROL BOARD CASING	1	ACXH10-08620	←	
⚠	14	TERMINAL BOARD COMPLETE	1	ACXA28C05970	←	O
⚠	15	ELECTRONIC CONTROLLER - MAIN	1	ACXA73C91620	ACXA73C91630	O
⚠	16	ELECTRONIC CONTROLLER-INDICATOR	1	ACXA73-45790	←	O
⚠	18	GENERATOR COMPLETE	1	ACXH94C01530	←	O
	19	INDICATOR HOLDER	1	ACXD93-22810	←	
⚠	20	SENSOR COMPLETE	1	ACXA50C17750	CWA50C2664	O
	21	DISCHARGE GRILLE COMPLETE	1	ACXE20C08220	←	
	22	BACK COVER CHASSIS	1	ACXD93-22420	←	
	23	FULCRUM	2	ACXH62-00810	←	
	24	VERTICAL VANE	10	ACXE24-04000	←	
	25	CONNECTING BAR - LEFT	2	ACXE26-02640	←	
	26	CONNECTING BAR - RIGHT	2	ACXE26-02650	←	
	27	HORIZONTAL VANE COMP - OUTER	1	ACXE24C04910	←	
	28	HORIZONTAL VANE COMP - INNER	1	ACXE24C04760	←	
⚠	29	AIR SWING MOTOR ASSY	1	ACXA98K00220	←	O
⚠	30	AIR SWING MOTOR - OUTER VANE	1	ACXA98-03560	←	O
⚠	31	AIR SWING MOTOR - INNER VANE	1	ACXA98-02950	←	O
	32	CAP - DRAIN TRAY	1	CWH521259	←	
⚠	33	REMOTE CONTROL COMPLETE	1	ACXA75C24381	←	O
	34	FRONT GRILLE COMPLETE	1	ACXE10C16960	ACXE10C16970	
	35	INTAKE GRILLE COMPLETE	1	ACXE22C04730	←	
	36	GRILLE DOOR COMPLETE	1	ACXE14C01440	←	
	37	AIR FILTER	2	ACXD00-03070	←	
	38	SCREW - FRONT GRILLE	6	XTT4+16CFJ	←	
	39	CAP - FRONT GRILLE	3	ACXH52-04000	←	
	40	PARTICULAR PLATE -LOCK	4	ACXD93-18690	←	
	43	DRAIN HOSE	1	ACXH85-00211	←	
	44	BOX SHAPED PLATE	1	ACXD66-03490	←	
	45	TUBE ASSY-COMPLETE	1	ACXT00C35810	ACXT00C39160	
⚠	47	LEAD WIRE-COMPLETE -WIFI	1	ACXA60C94030	←	O
	49	INSTALLATION PLATE	1	ACXH36-00880	←	
	50	BAG COMPLETE - INSTALLATION SCREW	1	CWH82C1705	←	
	51	OPERATING INSTRUCTION	1	ACXF55-34010	←	
	52	OPERATING INSTRUCTION	1	ACXF55-34020	←	
	53	INSTALLATION INSTRUCTION	1	ACXF60-47740	←	

SAFETY	REF. NO.	PART NAME & DESCRIPTION	QTY.	CS-TZ60ZKEW	CS-TZ71ZKEW	REMARK
	54	INSTALLATION INSTRUCTION	1	ACXF60-47750	←	
	55	INSTALLATION INSTRUCTION	1	ACXF60-47760	←	
	56	INSTALLATION INSTRUCTION	1	ACXF60-47770	←	
	57	INSTALLATION INSTRUCTION	1	ACXF60-47780	←	
	58	INSTALLATION INSTRUCTION	1	ACXF60-47790	←	
	59	INSTALLATION INSTRUCTION	1	ACXF60-47800	←	
	60	INSTALLATION INSTRUCTION	1	ACXF60-47810	←	
	61	INSTALLATION INSTRUCTION	1	ACXF60-47820	←	
	62	INSTALLATION INSTRUCTION	1	ACXF60-47830	←	
	63	INSTALLATION INSTRUCTION	1	ACXF60-47840	←	
	64	INSTALLATION INSTRUCTION	1	ACXF60-49260	←	
	65	INSTALLATION INSTRUCTION	1	ACXF60-49270	←	
	66	INSTALLATION INSTRUCTION	1	ACXF60-49280	←	
	67	INSTALLATION INSTRUCTION	1	ACXF60-49290	←	
	68	INSTALLATION INSTRUCTION	1	ACXF60-49300	←	
	69	INSTALLATION INSTRUCTION	1	ACXF60-49310	←	
	70	BAG	1	ACXG86-00130	←	
	71	SHOCK ABSORBER - LEFT	1	ACXG70-13280	←	
	72	SHOCK ABSORBER - RIGHT	1	ACXG70-13290	←	
	73	C.C.CASE	1	ACXG50-57182	←	
	74	MODEL LABEL	2	ACXF87-00700	ACXF87-00710	

(NOTE)

- All parts are supplied from PAPAMY, Malaysia (Vendor Code: 00029488).
- "O" marked parts are recommended to be kept in stock.