

22.2.2 CU-TZ35ZKE CU-TZ42ZKE CU-RZ35ZKE

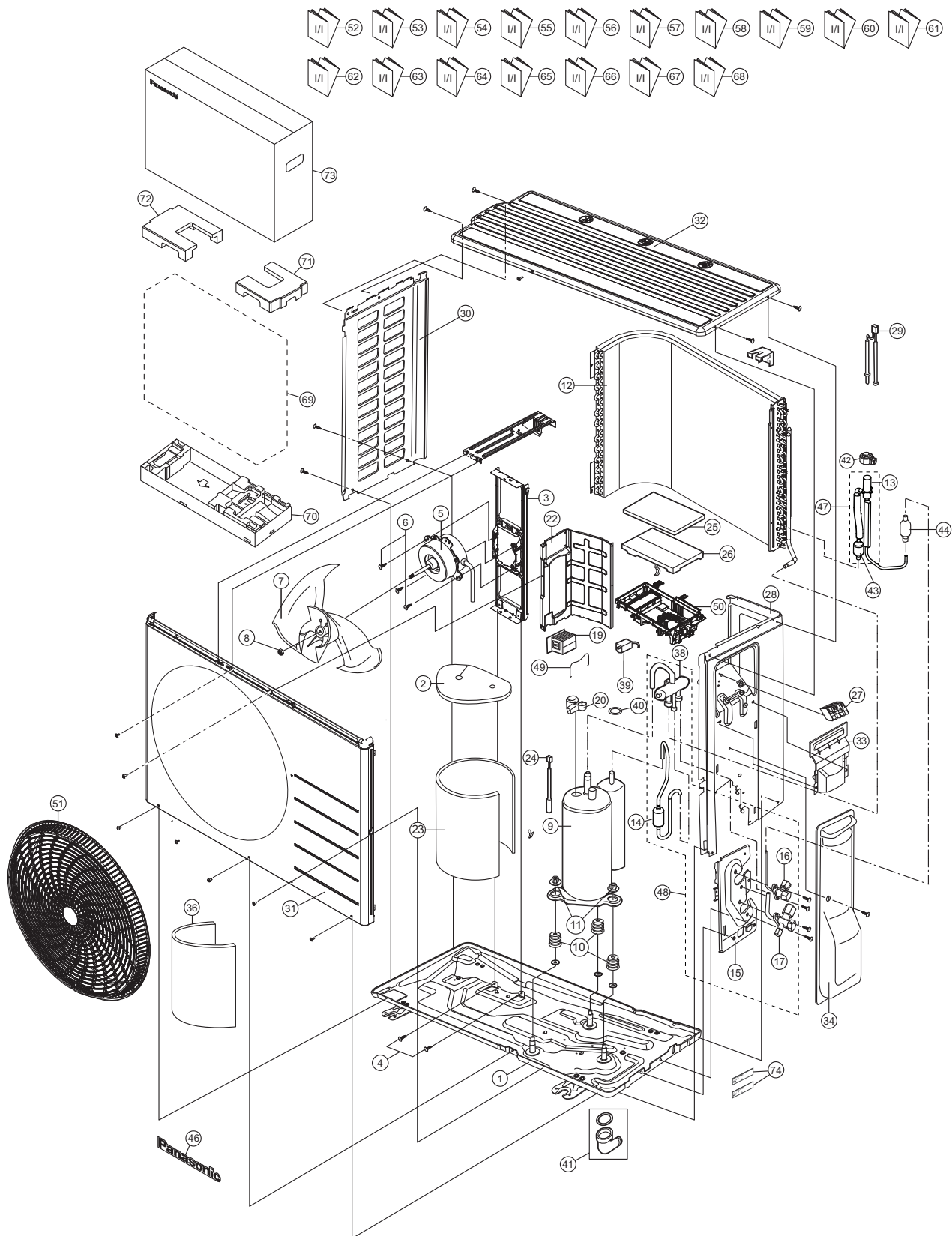

Note

The above exploded view is for the purpose of parts disassembly and replacement.
The non-numbered parts are not kept as standard service parts.

SAFETY	REF. NO.	PART NAME & DESCRIPTION	QTY.	CU-TZ35ZKE	CU-TZ42ZKE	CU-RZ35ZKE	REMARK
	1	BASE PAN ASSY	1	CWD52K1399	←	←	
	2	SOUND PROOF MATERIAL (COMP. TOP)	1	ACXG30-11800	←	←	
	3	FAN MOTOR BRACKET	1	CWD541157	←	←	
	4	SCREW - FAN MOTOR BRACKET	2	ACXH55-07140	←	←	
⚠	5	FAN MOTOR	1	L6CAYYYL0155	←	←	O
	6	SCREW - FAN MOTOR MOUNT	4	CWH55252J	←	←	
	7	PROPELLER FAN ASSY	1	CWH03K1100	←	←	
	8	NUT - PROPELLER FAN	1	CWH56053J	←	←	
⚠	9	COMPRESSOR	1	9RS102XRA21	←	←	O
	10	ANTI - VIBRATION BUSHING	3	CWH50077	←	←	
	11	NUT - COMPRESSOR MOUNT	3	CWH561096	←	←	
	12	CONDENSER	1	ACXB32C26850	ACXB32C26860	ACXB32C26850	O
	13	EXPANSION VALVE	1	ACXB05-01260	←	←	
	14	DISCHARGE MUFFLER(4 W.VALVE)	1	CWB121010	←	←	
	15	HOLDER COUPLING	1	CWH351233	←	←	
	16	2-WAYS VALVE (LIQUID)	1	ACXB02-03370	ACXB02-03310	ACXB02-03370	O
	17	3-WAY VALVE (GAS)	1	ACXB01-04540	ACXB01-02280	ACXB01-04540	O
⚠	19	REACTOR	1	CWG302314	←	←	O
	20	TERMINAL COVER	1	CWH171039A	←	←	
	22	SOUND PROOF BOARD	1	G0C752J00004	←	←	
	23	SOUND PROOF MATERIAL - COMP. BODY	1	ACXG30-11540	←	←	
⚠	24	SENSOR CO-COMP TEMP	1	ACXA50C17670	←	←	O
	25	CONTROL BOARD COVER-TOP	1	ACXH13-00450	←	←	
⚠	26	ELECTRONIC CONTROLLER - MAIN	1	ACXA73C94860R	ACXA73C94870R	ACXA73C94860R	O
⚠	27	TERMINAL BOARD ASSY	1	CWA28K1298	←	←	O
	28	CABINET SIDE PLATE CO.	1	ACXE04C00210	ACXE04C00110	ACXE04C00210	
⚠	29	SENSOR CO-AIR TEMP AND PIPE TEMP	1	CWA50C3267	←	←	O
	30	CABINET SIDE PLATE	1	ACXE04-00130A	←	←	
	31	CABINET FRONT PLATE CO.	1	CWE06C1566	←	←	
	32	CABINET TOP PLATE	1	CWE031230A	←	←	
	33	PLATE - C. B. COVER TERMINAL	1	CWH131301	←	←	
	34	CONTROL BOARD COVER CO.	1	CWH13C1359	←	←	
	36	SOUND PROOF MATERIAL - CABINET	1	CWG302994	←	←	
	38	4-WAYS VALVE	1	ACXB00-01290	←	←	O
⚠	39	V-COIL COMPLETE - 4-WAY VALVE	1	ACXA43C00250	←	←	O
	40	O-RING	1	ACXA43C07230	←	←	
	41	ACCESSORY-COMPLETE	1	ACXH82C21740	←	←	
⚠	42	V-COIL COMPLETE - EXP.VALVE	1	CWH151427	CWH151428	CWH151427	O
	43	STRAINER	1	CWB11094	←	←	
	44	DISCHARGE MUFFLER	1	CWB121021	←	←	
	46	PANASONIC BADGE	1	CWE373439	←	←	
	47	TUBE ASSY COMPLETE	1	ACXT00C43600	ACXT00C43610	ACXT00C43600	
	48	TUBE ASSY COMPLETE- 4 WAYS	1	ACXT00C43920	ACXT00C35310	ACXT00C43920	
	49	PLATE SPRING	1	CWH7080300J	←	←	
	50	CONTROL BOARD CASING	1	ACXH10-00750	←	←	
	51	DISCHARGE GRILLE	1	CWE201306	←	←	

SAFETY	REF. NO.	PART NAME & DESCRIPTION	QTY.	CU-TZ35ZKE	CU-TZ42ZKE	CU-RZ35ZKE	REMARK
	52	INSTALLATION INSTRUCTION	1	ACXF60-47850	←	←	
	53	INSTALLATION INSTRUCTION	1	ACXF60-47860	←	←	
	54	INSTALLATION INSTRUCTION	1	ACXF60-47870	←	←	
	55	INSTALLATION INSTRUCTION	1	ACXF60-47880	←	←	
	56	INSTALLATION INSTRUCTION	1	ACXF60-47890	←	←	
	57	INSTALLATION INSTRUCTION	1	ACXF60-47900	←	←	
	58	INSTALLATION INSTRUCTION	1	ACXF60-47910	←	←	
	59	INSTALLATION INSTRUCTION	1	ACXF60-47920	←	←	
	60	INSTALLATION INSTRUCTION	1	ACXF60-47930	←	←	
	61	INSTALLATION INSTRUCTION	1	ACXF60-47940	←	←	
	62	INSTALLATION INSTRUCTION	1	ACXF60-47950	←	←	
	63	INSTALLATION INSTRUCTION	1	ACXF60-49380	←	←	
	64	INSTALLATION INSTRUCTION	1	ACXF60-49390	←	←	
	65	INSTALLATION INSTRUCTION	1	ACXF60-49400	←	←	
	66	INSTALLATION INSTRUCTION	1	ACXF60-49410	←	←	
	67	INSTALLATION INSTRUCTION	1	ACXF60-49420	←	←	
	68	INSTALLATION INSTRUCTION	1	ACXF60-49430	←	←	
	69	BAG	1	CWG861078	←	←	
	70	BASE BOARD-COMPLETE	1	CWG62C1223	←	←	
	71	SHOCK ABSORBER - RIGHT	1	ACXG70-14420A	←	←	
	72	SHOCK ABSORBER - LEFT	1	ACXG70-14430A	←	←	
	73	C.C.CASE	1	ACXG50-48863	←	←	
	74	MODEL LABEL	2	ACXF85-99950	ACXF85-99960	ACXF87-01450	

(NOTE)

- All parts are supplied from PAPAMY, Malaysia (Vendor Code: 00029488).
- "O" marked parts are recommended to be kept in stock.