

22. Exploded View and Replacement Parts List

22.1 Indoor Unit

22.1.1 CS-TZ20WKEW CS-TZ25WKEW CS-TZ35WKEW CS-TZ42WKEW CS-TZ50WKEW CS-RZ20WKEW CS-RZ25WKEW CS-RZ35WKEW CS-RZ50WKEW

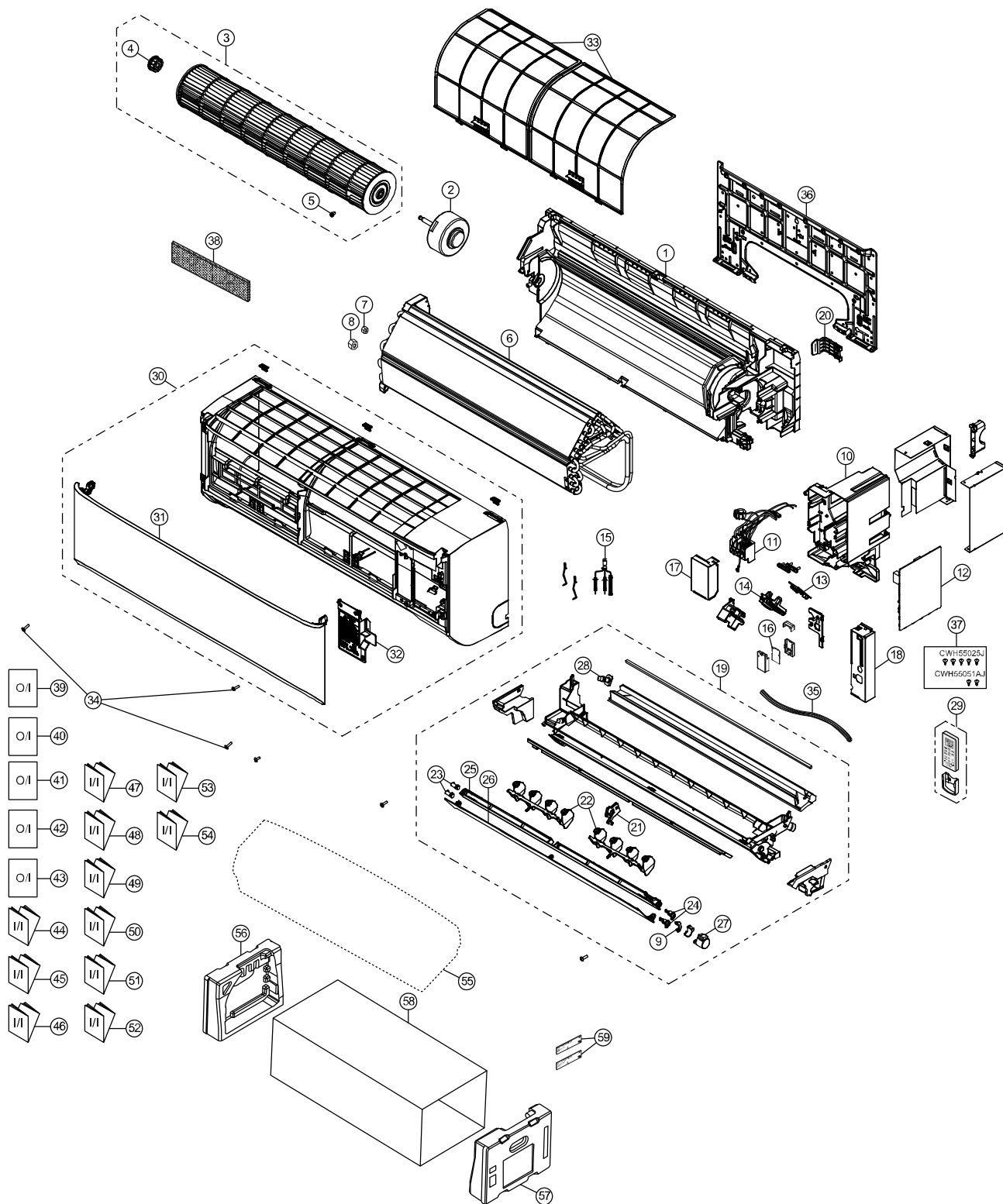

Note

The above exploded view is for the purpose of parts disassembly and replacement.
The non-numbered parts are not kept as standard service parts.

SAFETY	REF. NO.	PART NAME & DESCRIPTION	QTY.	CS-TZ42WKEW	CS-TZ50WKEW	REMARK
	1	CHASSIS COMPLETE	1	ACXD50C03410	←	
⚠	2	FAN MOTOR	1	L6CBYYL0311	←	O
	3	CROSS-FLOW FAN COMPLETE	1	ACXH02C01190	←	
	4	BEARING ASSY	1	CWH64K1006	←	
	5	SCREW - CROSS-FLOW FAN	1	CWH551146	←	
	6	EVAPORATOR	1	ACXB30C29360	←	
	7	FLARE NUT (LIQUID)	1	CWT251048	←	
	8	FLARE NUT (GAS)	1	CWT251032	←	
	9	LEVER ARM	1	ACXH65-00690	←	
	10	CONTROL BOARD CASING	1	ACXH10-07900	←	
⚠	11	TERMINAL BOARD COMPLETE	1	ACXA28C06010	ACXA28C06080	O
⚠	12	ELECTRONIC CONTROLLER - MAIN	1	ACXA73C60190	ACXA73C60200	O
⚠	13	ELECTRONIC CONTROLLER - INDICATOR	1	ACXA73-34540	←	O
	14	INDICATOR HOLDER	1	ACXD93-20780	←	
⚠	15	SENSOR COMPLETE	1	CWA50C2664	←	O
⚠	16	ELECTRONIC CONTROLLER - WIFI	1	ACXA73-28520	←	
	17	CONTROL BOARD COVER	1	ACXH13-08190	←	
	18	CONTROL BOARD COVER	1	ACXH13-08200	←	
	19	DISCHARGE GRILLE COMPLETE	1	ACXE20C05330	←	
	20	BACK COVER CHASSIS	1	ACXD93-18680	←	
	21	FULCRUM	1	ACXH62-00680	←	
	22	VERTICAL VANE	2	ACXE24-03470	←	
	23	SHAFT	2	ACXH63-01540	←	
	24	SHAFT	2	ACXH63-01570	←	
	25	HORIZONTAL VANE - INNER	1	ACXE24-03710	←	
	26	HORIZONTAL VANE - OUTER	1	ACXE24-03720	←	
⚠	27	AIR SWING MOTOR	1	ACXA98-02000	←	O
	28	CAP - DRAIN TRAY	1	CWH521259	←	
⚠	29	REMOTE CONTROL COMPLETE	1	ACXA75C18210	←	O
	30	FRONT GRILLE COMPLETE	1	ACXE10C11870	←	O
	31	INTAKE GRILLE COMPLETE	1	ACXE22C04140	←	
	32	GRILLE DOOR COMPLETE	1	ACXE14C01340	←	
	33	AIR FILTER	2	ACXD00-02860	←	
	34	SCREW - FRONT GRILLE	3	XTT4+16CFJ	←	O
	35	DRAIN HOSE	1	ACXH85-00200	←	
	36	INSTALLATION PLATE	1	ACXH36-00650	←	
	37	BAG COMPLETE - INSTALLATION SCREW	1	CWH82C1705	←	
	38	AIR PURIFYING FILTER	1	CWD00C1293	←	O
	39	OPERATING INSTRUCTION	1	ACXF55-27150	←	
	40	OPERATING INSTRUCTION	1	ACXF55-27160	←	
	41	OPERATING INSTRUCTION	1	ACXF55-27170	←	
	42	OPERATING INSTRUCTION	1	ACXF55-27180	←	
	43	OPERATING INSTRUCTION	1	ACXF55-27190	←	
	44	INSTALLATION INSTRUCTION	1	ACXF60-38530	←	
	45	INSTALLATION INSTRUCTION	1	ACXF60-38540	←	
	46	INSTALLATION INSTRUCTION	1	ACXF60-38550	←	
	47	INSTALLATION INSTRUCTION	1	ACXF60-38560	←	
	48	INSTALLATION INSTRUCTION	1	ACXF60-38570	←	
	49	INSTALLATION INSTRUCTION	1	ACXF60-38580	←	
	50	INSTALLATION INSTRUCTION	1	ACXF60-38590	←	
	51	INSTALLATION INSTRUCTION	1	ACXF60-38600	←	
	52	INSTALLATION INSTRUCTION	1	ACXF60-38610	←	

SAFETY	REF. NO.	PART NAME & DESCRIPTION	QTY.	CS-TZ42WKEW	CS-TZ50WKEW	REMARK
	53	INSTALLATION INSTRUCTION	1	ACXF60-38620	←	
	54	INSTALLATION INSTRUCTION	1	ACXF60-38630	←	
	55	BAG	1	ACXG86-00190	←	
	56	SHOCK ABSORBER (L)	1	ACXG70-11650	←	
	57	SHOCK ABSORBER (R)	1	ACXG70-11660	←	
	58	C.C.CASE	1	ACXG50-54750	←	
	59	MODEL LABEL	2	ACXF85-34700	ACXF85-34710	

(NOTE)

- All parts are supplied from PAPAMY, Malaysia (Vendor Code: 00029488).
- "O" marked parts are recommended to be kept in stock.