

U-12MF3E8
OUTDOOR UNIT

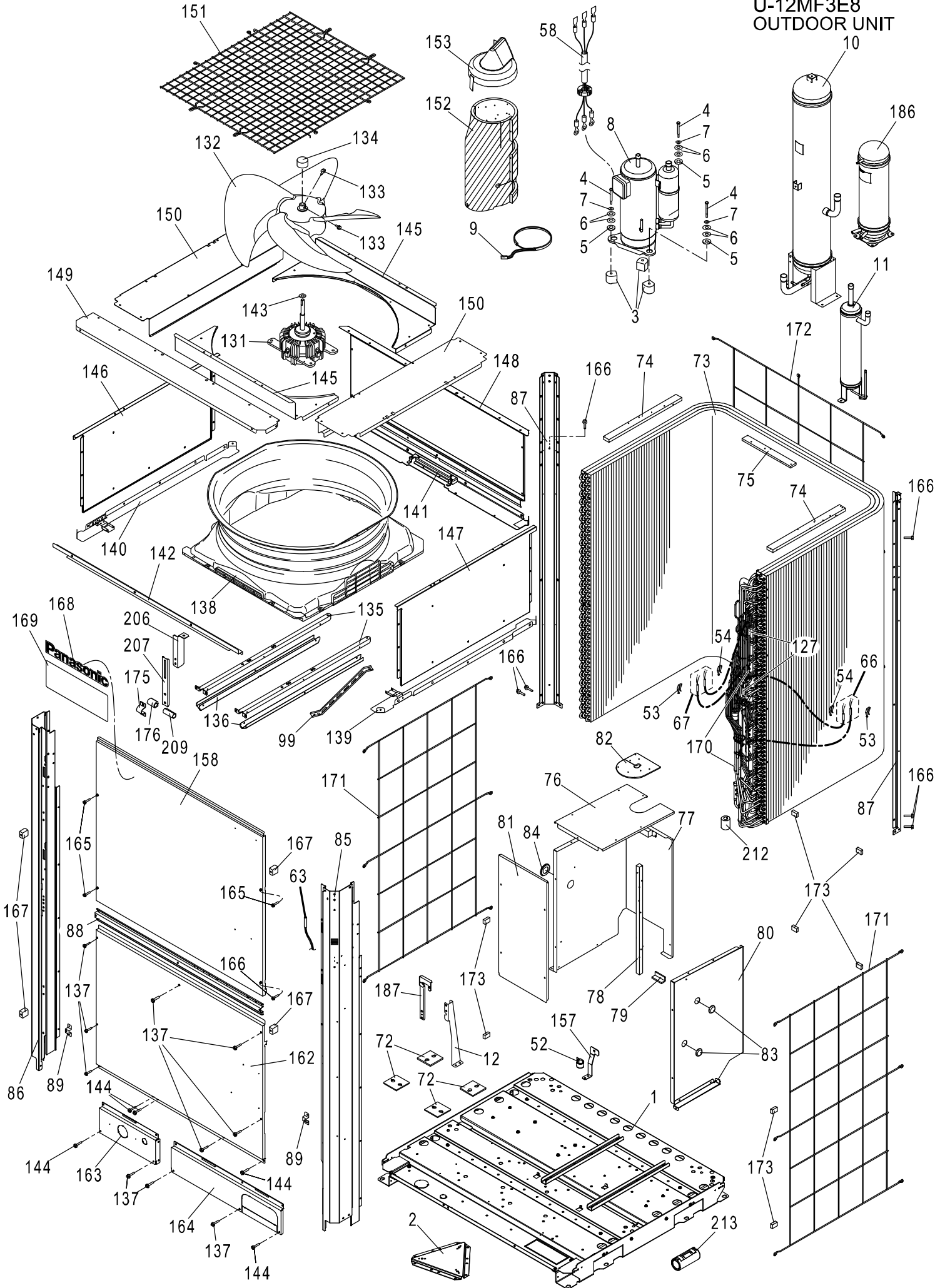

U-12MF3E8 OUTDOOR UNIT

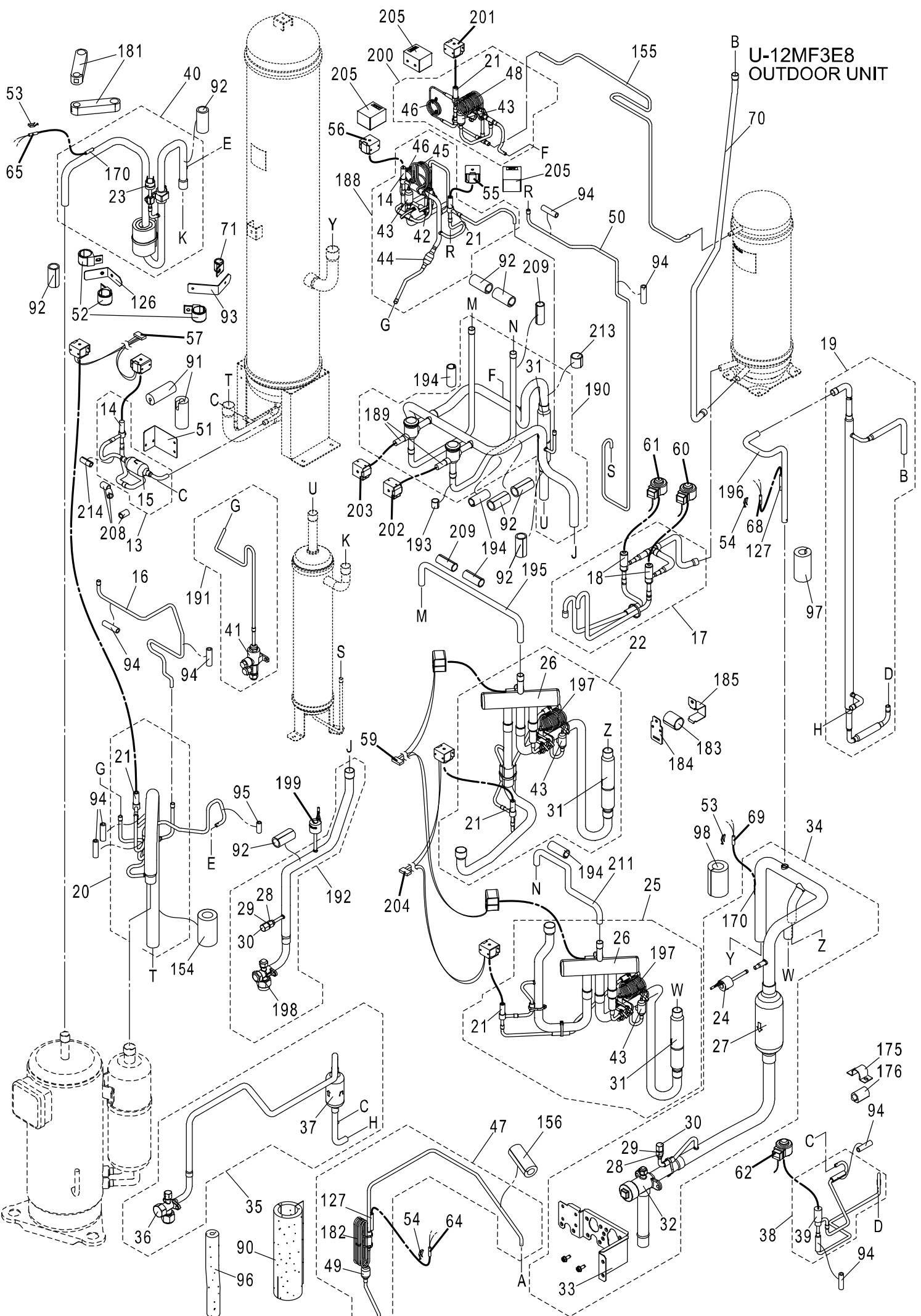

U-12MF3E8
OUTDOOR UNIT

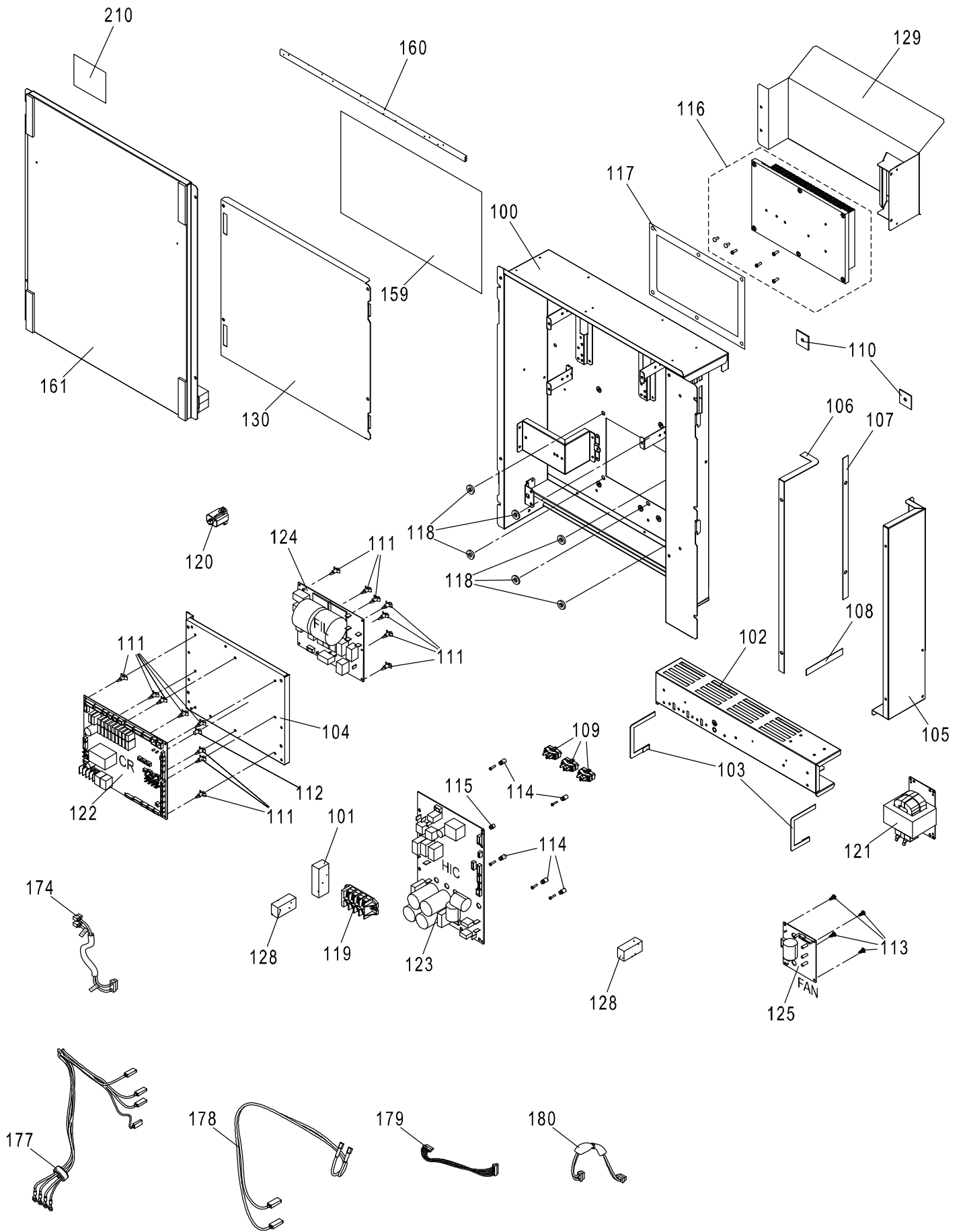

ATTENTION!

To ensure correct parts supply, please let us know the following,

Part No. when you make service parts order:

U-12MF3E8

1.Part No. 2.Description 3.Q'ty 4.Volts-Hz-Ph 5.Product Model No.

OUTDOOR UNIT

KeyNo.	Description	12Q'ty	Reference No.	Available in EyesG21
1	BASE PAN-COMPLETE	1	ACXD52C00520	
2	PARTICULAR PLATE COMPLETE	1	CWD91C0268A	
3	ANTI-VIBRATION BUSHING	3	CWH501110	o
4	SCREW	3	CWH551325	o
5	SPACER	3	CWH541154	o
6	PLAIN WASHER	6	XWE65H30V	o
7	WASHER	3	CWH571081	o
*	8 COMPRESSOR (ACXB09-05100)	1	5JD650ZCA22	o
*	9 HEATER (CH1)	1	CWA341105	o
10	ACCUMLATOR ASSY	1	CWB13K1092	o
11	OIL SEPARATER	1	CWB161017	o
12	PARTICULAR PLATE	1	CWD912658	
*	13 2-WAYS VALVE ASSY	1	ACXB02K00110	
*	14 2-WAYS VALVE	2	CWB021604	o
15	STRAINER	1	CWB111092	o
16	MULTIBENT TUBE	1	ACXT30-82490	
*	17 EXPANTION VALVE ASSY	1	ACXB05K00210	
*	18 EXPANTION VALVE	2	ACXB05-01010	o
19	TUBE ASSY	1	ACXT00-52270	
*	20 2-WAYS VALVE ASSY	1	ACXB02K00100	
*	21 2-WAYS VALVE	5	CWB021580	o
22	4-WAYS VALVE ASSY	1	ACXB00K00710	
*	23 PRESSURE SWITCH	1	CWA101033	o
*	24 PRESSURE SENSING DEVICE (LPS)	1	ACXA50-04600	o
*	25 4-WAYS VALVE ASSY	1	ACXB00K00720	
*	26 4-WAYS VALVE	2	CWB001094	o
27	STRAINER	1	CWB111072	
28	TUBE CONNECTER	2	CWT291170	
29	CHECK VALVE	2	CWB031094	o
30	CAP	2	CWH521254	
31	CHECK VALVE	3	CWB031111	o
32	3-WAYS VALVE	1	ACXB01-03810	o
33	PARTICULAR PLATE	1	ACXD90-21450	
34	TUBE ASSY	1	ACXT00-52080	
35	TUBE ASSY	1	ACXT00-52390	
36	3-WAYS VALVE	1	CWB011852	o
37	STRAINER	1	CWB111067	o
*	38 EXPANTION VALVE ASSY	1	ACXB05K00200	
*	39 EXPANTION VALVE	1	CWB051050	o
40	TUBE ASSY	1	ACXT00-52200	
41	3-WAYS VALVE	1	CWB011692	o
42	CHECK VALVE	1	CWB031102	o
43	STRAINER	4	CWB111068	o
44	STRAINER	1	CWB111069	o
*	45 CAPILLARY TUBE	1	CWB153570	o
*	46 CAPILLARY TUBE	2	CWB153236	o
*	47 CAPILLARY TUBE ASSY	1	ACXB15K05220	o
*	48 CAPILLARY TUBE	1	ACXB15-19000	o
49	STRAINER	1	CWB111070	o
50	MULTIBENT TUBE	1	ACXT30-83220	

NOTE: Metal and plastic parts will be supplied basically with necessary heat insulation pads or packing. Each key number with an asterisk (*) means the recommended service parts.

ATTENTION!

To ensure correct parts supply, please let us know the following,

Part No. when you make service parts order:

U-12MF3E8

1.Part No. 2.Description 3.Q'ty 4.Volts-Hz-Ph 5.Product Model No.

OUTDOOR UNIT

KeyNo.	Description	12Q'ty	Reference No.	Available in EyesG21
51	L-PIECE	1	ACXD70-02010	
52	C-PIECE	4	CWD791019	
53	PLATE SPRING	4	CWH711013	
54	PLATE SPRING	4	CWH711025	
*	55 V-COIL COMPLETE (BPV)	1	CWA43C2670	o
*	56 V-COIL COMPLETE (ORVR)	1	ACXA43C05770	o
*	57 V-COIL COMPLETE (ACV,SAVE)	1	ACXA43C05780	o
*	58 LEAD WIRE-COMPLETE	1	CWA68C2193	
*	59 V-COIL COMPLETE (SCV1,2)	1	ACXA43C05720	o
*	60 V-COIL COMPLETE (MOV1)	1	ACXA43C05660	o
*	61 V-COIL COMPLETE (MOV2)	1	ACXA43C05680	o
*	62 V-COIL COMPLETE (MOV4)	1	ACXA43C06070	o
*	63 THERMISTOR (TO)	1	ACXA50C13870	o
*	64 THERMISTOR (OIL1)	1	ACXA50C13840	o
*	65 THERMISTOR (DISCH1)	1	ACXA50C13880	o
*	66 THERMISTOR (EXL1,2)	1	ACXA50C13890	o
*	67 THERMISTOR (EXG1,2)	1	ACXA50C13900	o
*	68 THERMISTOR (SCG)	1	ACXA50C13860	o
*	69 THERMISTOR (SCT)	1	ACXA50C13850	o
70	MULTIBENT TUBE	1	ACXT30-83210	
71	C-PIECE	1	CWD791020	
72	SPACER	4	CWH541156	o
73	FIN & TUBE CONDENSER COMPLETE	1	ACXB32C15110	o
74	EPT SEAL	2	CWD15A35-450	
75	EPT SEAL	1	CWD10A35-300	
76	SOUND-PROOF BOARD	1	ACXH15-02440	
77	SOUND-PROOF BOARD ASSY	1	ACXH15K00630	
78	EPT SEAL	1	CWD20A20-580	
79	EPT SEAL	1	CWD3A40-60	
80	SOUND-PROOF BOARD ASSY	1	ACXH15K00760	
81	SOUND-PROOF BOARD	1	ACXH15-02450	
82	RUBBER	1	CWG251091	
83	RUBBER	2	CWG251068	
84	RUBBER	1	CWG251069	
85	CABINET SIDE PLATE ASSY	1	CWE04K1199A	o
86	CABINET SIDE PLATE	1	CWE041843A	o
87	CABINET SIDE PLATE	2	CWE041844A	o
88	PARTICULAR PLATE	1	ACXD90-16650	
89	PARTICULAR PIECE	2	CWD934068	
90	ADH. POLY-E. FOAM	1	CWG123162	
91	ADH. POLY-E. FOAM	2	CWG123541	
92	RUBBER	7	CWG251065	
93	PARTICULAR PIECE	1	ACXD93-20000	
94	RUBBER	8	CWG251059	
95	RUBBER	1	CWG251058	
96	ADH. POLY-E. FOAM	1	CWG123542	
97	ADH. POLY-E. FOAM	1	CWG123545	
98	ADH. POLY-E. FOAM	1	CWG123547	
99	PARTICULAR PLATE	1	CWD912644	
100	CONTROL BOARD ASSY	1	ACXH10K02170	

NOTE: Metal and plastic parts will be supplied basically with necessary heat insulation pads or packing. Each key number with an asterisk (*) means the recommended service parts.

ATTENTION!

To ensure correct parts supply, please let us know the following,

Part No. when you make service parts order:

U-12MF3E8

1.Part No. 2.Description 3.Q'ty 4.Volts-Hz-Ph 5.Product Model No.

OUTDOOR UNIT

KeyNo.	Description	12Q'ty	Reference No.	Available in EyesG21	
101	EPT SEAL (FLAMEPROOF)	1	CWDN20A30-75		
102	DUCT ASS.Y	1	CWD22K1002		
103	ADH. POLY-E. FOAM	2	CWG123548		
104	PARTICULAR PLATE	1	CWD912663		
105	DUCT	1	CWD221091		
106	ADH. POLY-E. FOAM	1	CWG123549		
107	ADH. POLY-E. FOAM	1	CWG123550		
108	POLY-E.FOAM	1	CWE2A15-110		
109	HOLDER-P.S. CORD	3	ACXH31-01240		
110	ADH. POLY-E. FOAM	2	CWG123558		
111	SPACER	15	CWH541203		
112	SPACER	1	CWH541204		
113	SPACER	4	CWH541205		
114	SPACER	5	CWH541206		
115	SPACER	1	CWH541207		
116	HEATSINK	1	ACXA58K00010		
117	INSULATION	1	CWA621014		
118	SPACER	6	CWH541153		
*	119	TERMINAL BOARD ASSY	1	CWA28K1109	o
*	120	PTC THERMISTORS	1	D4DDG1010001	o
*	121	FIXED INDUCTORS	1	G0C252K00001	o
*	122	PC BOARD W/COMPONENT	1	ACXA73C63070	o
*	123	ELEC.CONTROLLER-COMplete(HIC)	1	CWA73C9053	o
*	124	ELECTRONIC CONTROLLER (FIL)	1	CWA748323	o
*	125	ELECTRONIC CONTROLLER (FAN)	1	ACXA73-36140	o
	126	PARTICULAR PIECE	1	ACXD93-19970	
	127	STRAIGHT TUBE	4	CWT103083	
	128	EPT SEAL (FLAMEPROOF)	2	CWDN20A25-55	
	129	DUCT ASS.Y	1	CWD22K1004	
	130	PARTICULAR PLATE	1	ACXD90-21380	
*	131	MOTOR (LARGE DC)	1	CWDMSBG75SY	o
*	132	FAN ASSY	1	CWH03K1082	o
	133	BOLT	2	XVG6A10FJ4	o
	134	CAP	1	CWH521248	
	135	FAN MOTOR BRACKET	2	ACXD54-03090	o
	136	AIR REGULATING PLATE	2	CWD211007	o
	137	SCREW	10	CWH551448	o
	138	AIR GUIDER P.F.	1	CWD311030	
	139	FAN MOTOR BRACKET ASSY	1	CWD54K1087	
	140	FAN MOTOR BRACKET ASSY	1	CWD54K1088	
	141	FAN MOTOR BRACKET ASSY	1	CWD54K1090	
	142	FAN MOTOR BRACKET	1	CWD541261	
	143	SPACER	1	CWH541158	
	144	SCREW	5	CWH551326A	
	145	CABINET TOP PLATE-COMplete	2	CWE03C1171	o
	146	CABINET SIDE PLATE	1	ACXE04-09270A	o
	147	CABINET SIDE PLATE	1	ACXE04-09280A	o
	148	CABINET REAR PLATE	1	ACXE02-01890A	
	149	CABINET TOP PLATE	1	CWE031226A	o
	150	CABINET TOP PLATE	2	CWE031227A	o

NOTE: Metal and plastic parts will be supplied basically with necessary heat insulation pads or packing. Each key number with an asterisk (*) means the recommended service parts.

ATTENTION!

To ensure correct parts supply, please let us know the following,

Part No. when you make service parts order:

U-12MF3E8

1.Part No. 2.Description 3.Q'ty 4.Volts-Hz-Ph 5.Product Model No.

OUTDOOR UNIT

KeyNo.	Description	12Q'ty	Reference No.	Available in EyesG21
151	WIRE NET ASSY	1	CWD04K1004A	o
152	SOUND PROOF MATERIAL	1	CWG302976	o
153	RAIN COVER-COMplete	1	CWH81C1005	o
154	ADH. POLY-E. FOAM	1	CWG123167	
155	MULTIBENT TUBE	1	ACXT30-83230	
156	ADH. POLY-E. FOAM	1	CWG123173	
* 157	PARTICULAR PLATE	1	ACXD90-22770	
158	CABINET FRONT PLATE-COMplete	1	CWE06C1549	o
* 159	WIRING DIAGRAM (CU)	1	ACXF22-06750	
160	POLY-E.FOAM	1	CWE2A25-550	
161	CONTROL BOARD COVER-COMplete	1	CWH13C1346	o
162	CABINET FRONT PLATE	1	CWE061391A	o
163	CABINET FRONT PLATE-COMplete	1	CWE06C1550	o
164	CABINET FRONT PLATE-COMplete	1	CWE06C1552	o
165	SCREW	3	CWH551333A	
166	SCREW	7	CWH551332A	
167	SPACER	4	CWH541152	
168	BADGE	1	CWE373439	o
169	BADGE	1	ACXE37-02510	
170	STRAIGHT TUBE	4	CWT102194	
171	WIRE NET.RESIN NET	2	ACXD04-00050A	
172	WIRE NET.RESIN NET	1	ACXD04-00070A	
173	EPT SEAL (FLAMEPROOF)	8	CWDN20A20-30	
* 174	LEAD WIRE-COMplete (63PH)	1	CWA68C2173	
* 175	C-PIECE	2	CWD791023	
* 176	RUBBER	2	CWG251074	
* 177	LEAD WIRE-COMplete	1	ACXA60C70660	
* 178	LEAD WIRE-COMplete (RE)	1	CWA68C2186	
* 179	LEAD WIRE-COMplete (L-POW (R)	1	CWA68C2188	
* 180	LEAD WIRE-COMplete (CR-AC-IN)	1	CWA68C2192	
181	RUBBER	2	ACXG25-02020	
182	CAPILLARY TUBE	1	CWB153237	o
183	RUBBER	1	ACXG25-02040	
184	PARTICULAR PIECE	1	ACXD93-18190	
185	PARTICULAR PIECE	1	ACXD93-18200	
186	RECEIVER ASSY	1	CWB14K1018	o
187	PARTICULAR PLATE-COMplete	1	ACXD90C02620	
188	TUBE ASSY	1	ACXT00-52260	
189	2-WAYS VALVE	2	ACXB02-02640	o
190	TUBE ASSY	1	ACXT00-52240	
191	TUBE ASSY	1	ACXT00-52110	
192	TUBE ASSY	1	ACXT00-52400	
193	RUBBER	1	ACXG25-01980	
194	RUBBER	4	ACXG25-01920	
195	MULTIBENT TUBE	1	ACXT30-82970	
* 196	TUBE ASSY	1	ACXT00-52090	
197	CAPILLARY TUBE	2	CWB153235	o
198	3-WAYS VALVE	1	ACXB01-03800	o
* 199	PRESSURE SENSING DEVICE (HPS)	1	ACXA50-04610	o
200	TUBE ASSY	1	ACXT00-52120	

NOTE: Metal and plastic parts will be supplied basically with necessary heat insulation pads or packing. Each key number with an asterisk (*) means the recommended service parts.

