

# 21. Exploded View and Replacement Parts List

## 21.1 Indoor Unit

### 21.1.1 WH-ADC0912K9E8

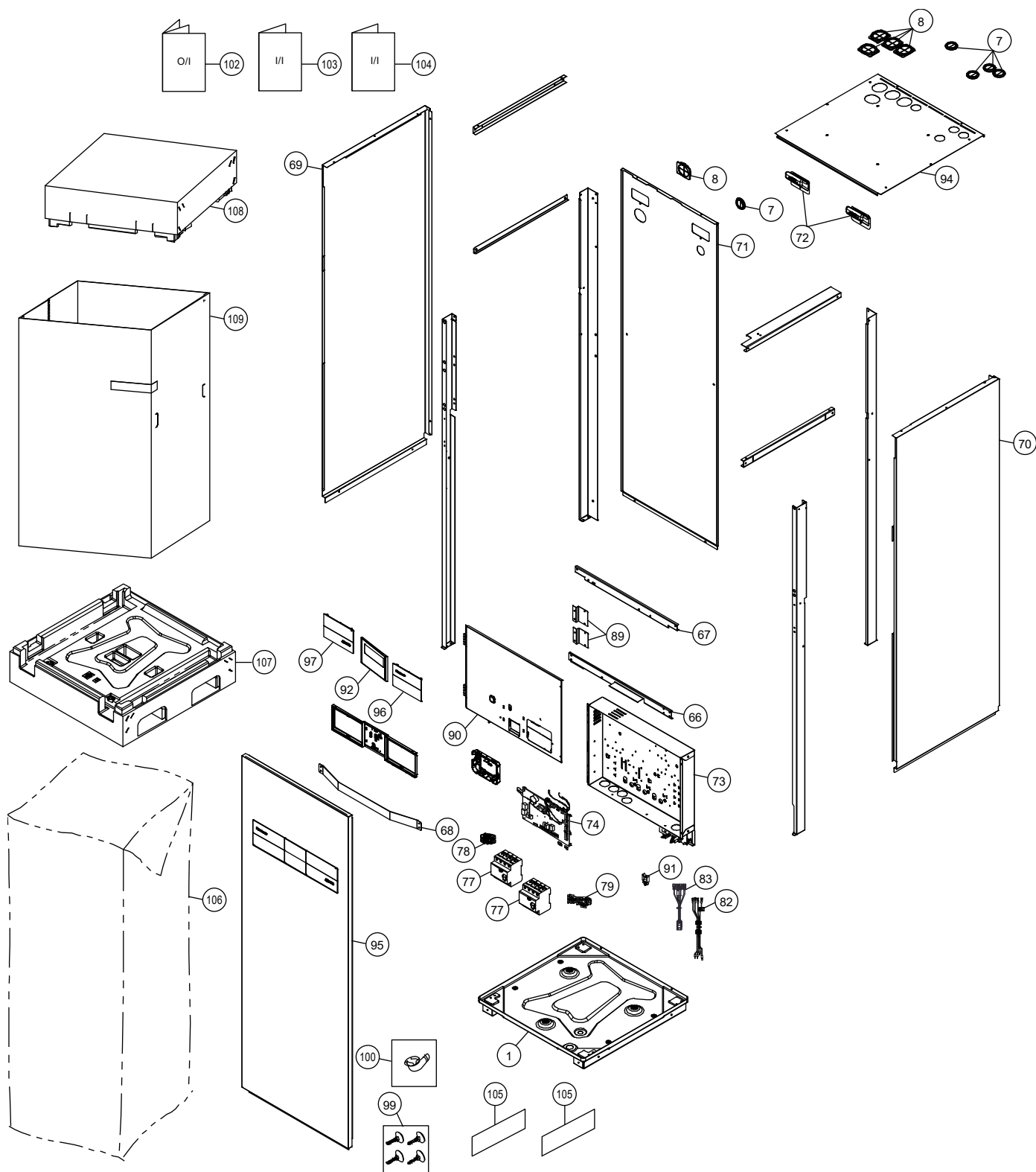

**Note:**  
The above exploded view is for the purpose of parts disassembly and replacement.  
The non-numbered parts are not kept as standard service parts.

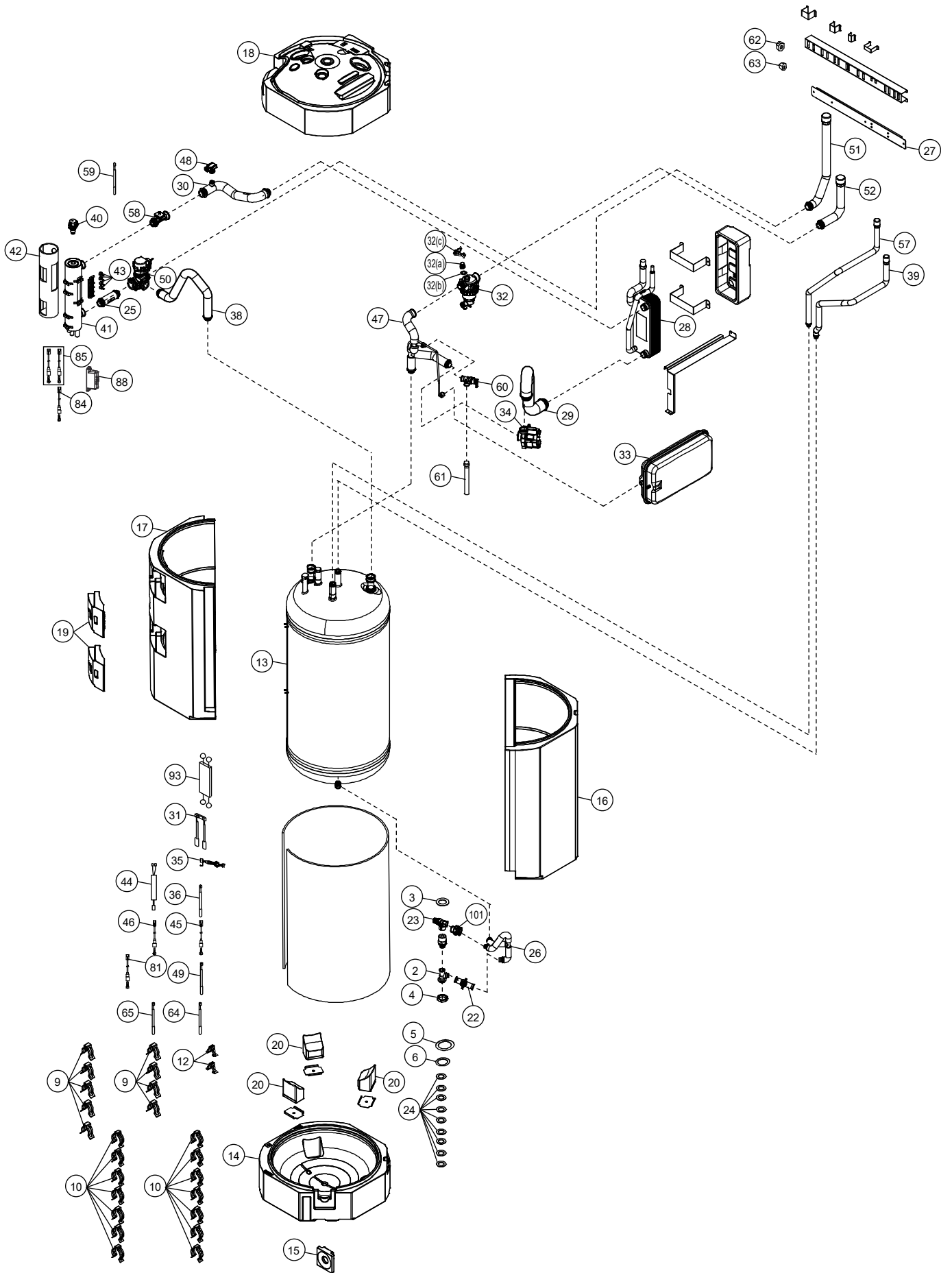

**Note:**

The above exploded view is for the purpose of parts disassembly and replacement.  
The non-numbered parts are not kept as standard service parts.

SAFETY	REF. NO.	DESCRIPTION & NAME	QTY.	WH-ADC0912K9E8	REMARK
	1	CHASSIS - COMPLETE	1	ACXD50C04840	
	2	TUBE CONNECTER	1	ACXT29-02570	
	3	O-RING (ID: 27mm)	1	ACXB81-07070	
	4	NUT	1	ACXH56-01370	
	5	O-RING (ID: 25.70mm)	1	ACXB81-06910	
	6	O-RING (ID: 8.1mm)	1	B811179	
	7	O-RING (ID: 35mm)	5	ACXB81-00030	
	8	O-RING (ID: 54mm X 47mm)	5	ACXB81-00040	
	9	RETAINING RING	9	H581007	
	10	RETAINING RING	14	ACXH58-00370	
	12	RETAINING RING	2	H581038	
	13	TANK COMPLETE	1	ACXB56C01210	
	14	FOAMED POLYSTYRENE	1	ACXG07-07690	
	15	FOAMED POLYSTYRENE	1	ACXG07-07700	
	16	FOAMED POLYSTYRENE	1	ACXG07-07710	
	17	FOAMED POLYSTYRENE	1	ACXG07-07720	
	18	FOAMED POLYSTYRENE	1	ACXG07-07731	
	19	FOAMED POLYSTYRENE	2	ACXG07-07740	
	20	FOAMED POLYSTYRENE	3	ACXG07-07750	
	22	DRAIN VALVE	1	ACXB65C00111	
	23	PRESSURE AND TEMP RELIEF VALVE (TANK)	1	ACXB62-00920	
	24	O-RING (ID: 13.60mm)	9	ACXB81-00010	
	25	TUBE ASSY - COMPLETE	1	ACXT00C37270	
	26	TUBE ASSY	1	ACXT00-77551	
	27	CONNECTING BAR	1	ACXE26-02841	
	28	HOT WATER COIL - COMPLETE	1	ACXB90C01610	
	29	TUBE ASSY - COMPLETE	1	ACXT00C45990	
	30	TUBE ASSY - COMPLETE	1	ACXT00C46000	
	31	SENSOR CO. (TANK TEMP CN-TH2)	1	ACXA50C18700	O
	32	FILTER COMPLETE	1	ACXB51C00110	O
	32(a)	PLUG	1	ACXB82-00840	
	32(b)	PACKING	1	ACXB81-06810	
	32(c)	RETAINING RING	1	H581038	
	33	RECEIVER	1	ACXB14-00720	
	34	WATER PUMP	1	ACXB53-00850	O
	35	LEAD WIRE FOR WATER PUMP	1	ACXA60C73630	O
	36	LEAD WIRE - CO. (HEATER - HEAT1)	1	A68C1437	
	38	TUBE ASSY - COMPLETE	1	ACXT00C46010	
	39	TUBE ASSY - COMPLETE	1	ACXT00C47520	
	40	AIR PURGE VALVE	1	ACXB62-00130	

SAFETY	REF. NO.	DESCRIPTION & NAME	QTY.	WH-ADC0912K9E8	REMARK
	41	HEATER ASS'Y	1	ACXA34K00620	O
	42	SOUND PROOF MATERIAL	1	ACXG30-10530	
	43	THERMOSTAT	4	A151074	O
	44	LEAD WIRE - CO. (CN-OLP1)	1	ACXA60C93670	O
	45	LEAD WIRE - CO. (OLP & HEATER)	1	ACXA60C98060	O
	46	LEAD WIRE - CO. (HEATER - HEAT2)	1	A68C1438	
	47	TUBE ASSY - COMPLETE	1	ACXT00C47510	
	48	BOILER PRESSURE TRANSDUCER	1	ACXB62-01110	
	49	LEAD WIRE - CO. (CN-DPS)	1	ACXA60C93661	
	50	MOTORIZED 3-WAY VALVE	1	ACXB62-00092	
	51	TUBE ASSY - COMPLETE	1	ACXT00C45370	
	52	TUBE ASSY - COMPLETE	1	ACXT00C45260	
	57	TUBE ASSY - COMPLETE	1	ACXT00C41030	
	58	FLOW SWITCH	1	ACXB62-00932	
	59	LEAD WIRE - FLOW SENSOR	1	ACXA60C82910	O
	60	PRESSURE RELIEF VALVE	1	ACXB62-00740	
	61	TUBE ASSY	1	ACXT00-77260	
	62	FLARE NUT (5/8)	1	T251032	
	63	FLARE NUT (1/4)	1	T251063	
	64	SENSOR - CO. (WATER IN OUT, REF TEMP SENSOR CN-TH1)	1	ACXA50C16380	O
	65	SENSOR - CO. (HEX WATER OUTLET TEMP CN-TH3)	1	ACXA50C16390	O
	66	CONNECTING BAR	1	ACXE26-02860	
	67	CONNECTING BAR	1	ACXE26-02870	
	68	CONNECTING BAR	1	ACXE26-02880	
	69	CABINET SIDE PLATE (L)	1	ACXE04-13290A	
	70	CABINET SIDE PLATE (R)	1	ACXE04-13300A	
	71	CABINET REAR PLATE	1	ACXE02-03400	
	72	HANDLE	2	ACXE16-00300	
	73	CONTROL BOARD	1	ACXH10-10250	
	74	ELECTRONIC CONTROLLER - MAIN	1	ACXA73C97380	O
	77	RESIDUAL CURRENT - CIRCUIT BREAKER	2	ACXA18-00021	O
	78	TERMINAL BOARD ASSY (1, 2, 3)	1	A28K1238	O
	79	TERMINAL BOARD ASS'Y	1	A28K1240	O
	81	LEAD WIRE - CO. (WIRE1)	1	ACXA60C98080	
	82	LEAD WIRE - CO. (WIRE2)	1	ACXA61C00470	
	83	LEAD WIRE - CO. (HEATER - CON)	1	ACXA60C98370	O
	84	LEAD WIRE - CO. (HEATER1 - A)	1	ACXA60C98360	O
	85	LEAD WIRE - CO. (HEATER2 - A)	2	ACXA60C94860	
	88	TERMINAL COVER	1	H171051	
	89	HINGE	2	H611006	

SAFETY	REF. NO.	DESCRIPTION & NAME	QTY.	WH-ADC0912K9E8	REMARK
	90	CONTROL BOARD COVER	1	ACXH13-09290	
	91	HOLDER - P.S. CORD	1	ACXH31-00210	
	92	REMOTE CONTROL COMPLETE	1	ACXA75C23211	O
	93	LEAD WIRE FOR REMOTE CONTROL	1	ACXA60C93691	O
	94	CABINET TOP PLATE	1	ACXE03-04880	
	95	CABINET FRONT PLATE	1	ACXE06-05161A	
	96	DECORATION BASE ASS'Y	1	ACXE35K03630	
	97	DECORATION BASE ASS'Y	1	ACXE35K03640	
	99	ACCESSORY ADJUSTABLE FEET	1	H82C2112	
	100	ACCESSORY CO. (DRAIN ELBOW)	1	G87C900	
	101	SOCKET COMPLETE	1	ACXT27-00090	
	102	OPERATING INSTRUCTION	1	ACXF55-37270	
	103	INSTALLATION INSTRUCTION	1	ACXF60-52940	
	104	INSTALLATION INSTRUCTION	1	ACXF60-52950	
	105	MODEL LABEL	2	ACXF87-10110	
	106	BAG	1	ACXG86-04782	
	107	BASE BOARD - COMPLETE	1	ACXG62C02790	
	108	TOP BOARD COMPLETE	1	ACXG60C00300	
	109	C.C. CASE	1	ACXG50-61791	

**Note:**

- All parts are supplied from PHVACCZ, Czech (Vendor Code: 00029407).
- "O" marked parts are recommended to be kept in stock.