

22. Exploded View and Replacement Parts List

22.1 Water System

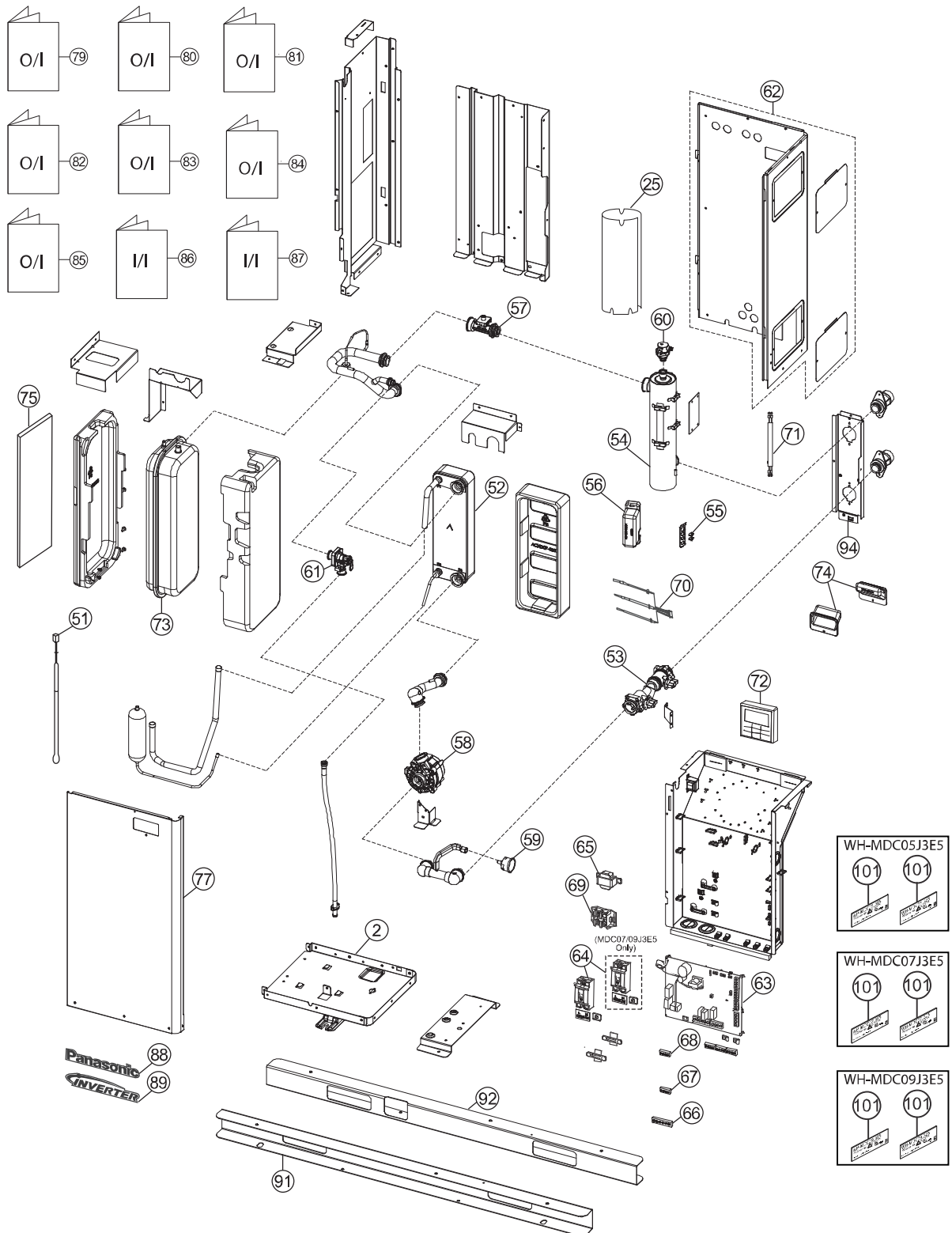

Note:
 The above exploded view is for the purpose of parts disassembly and replacement.
 The non-numbered parts are not kept as standard service parts.

22.2 Refrigerant System

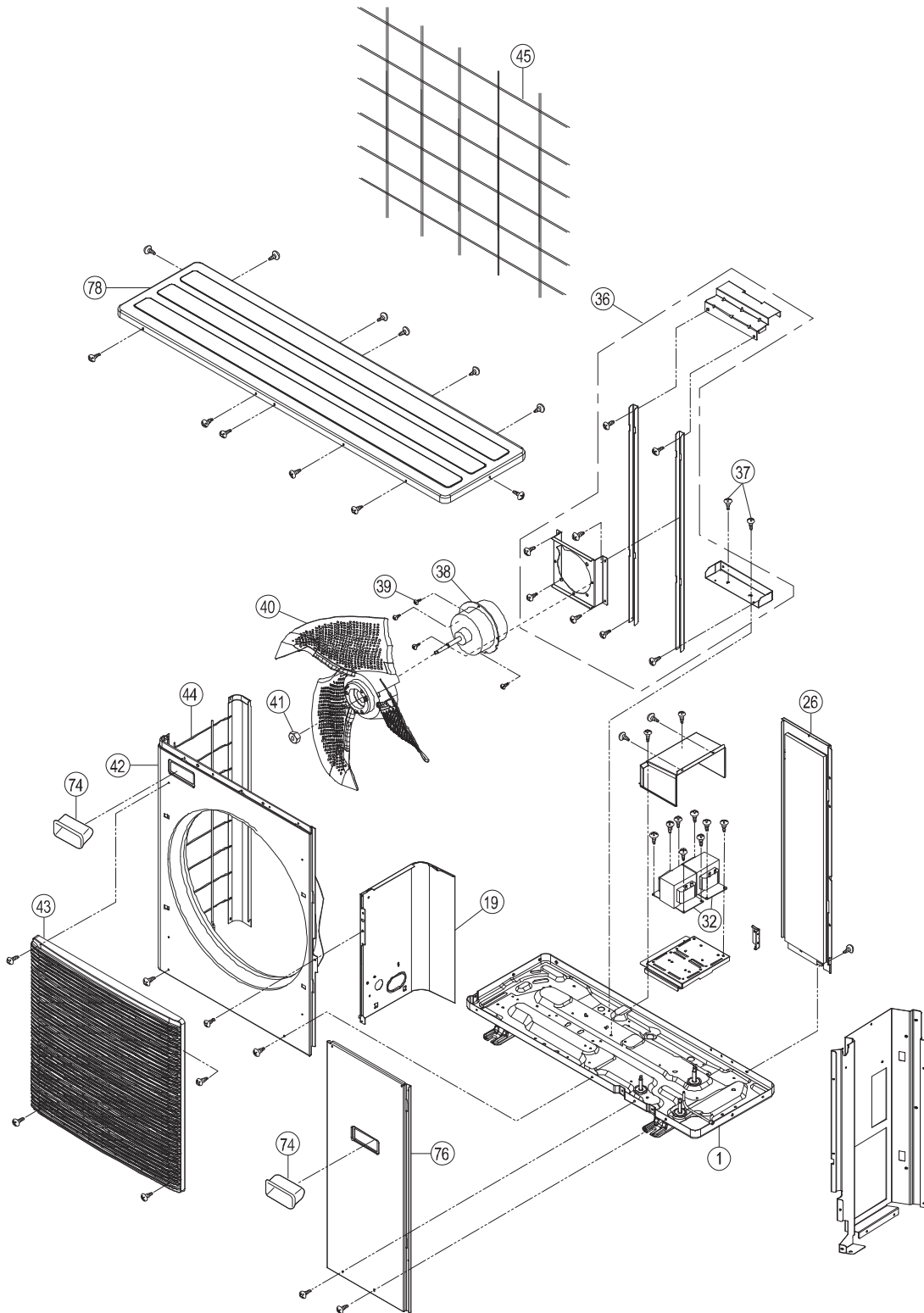

Note:
The above exploded view is for the purpose of parts disassembly and replacement.
The non-numbered parts are not kept as standard service parts.

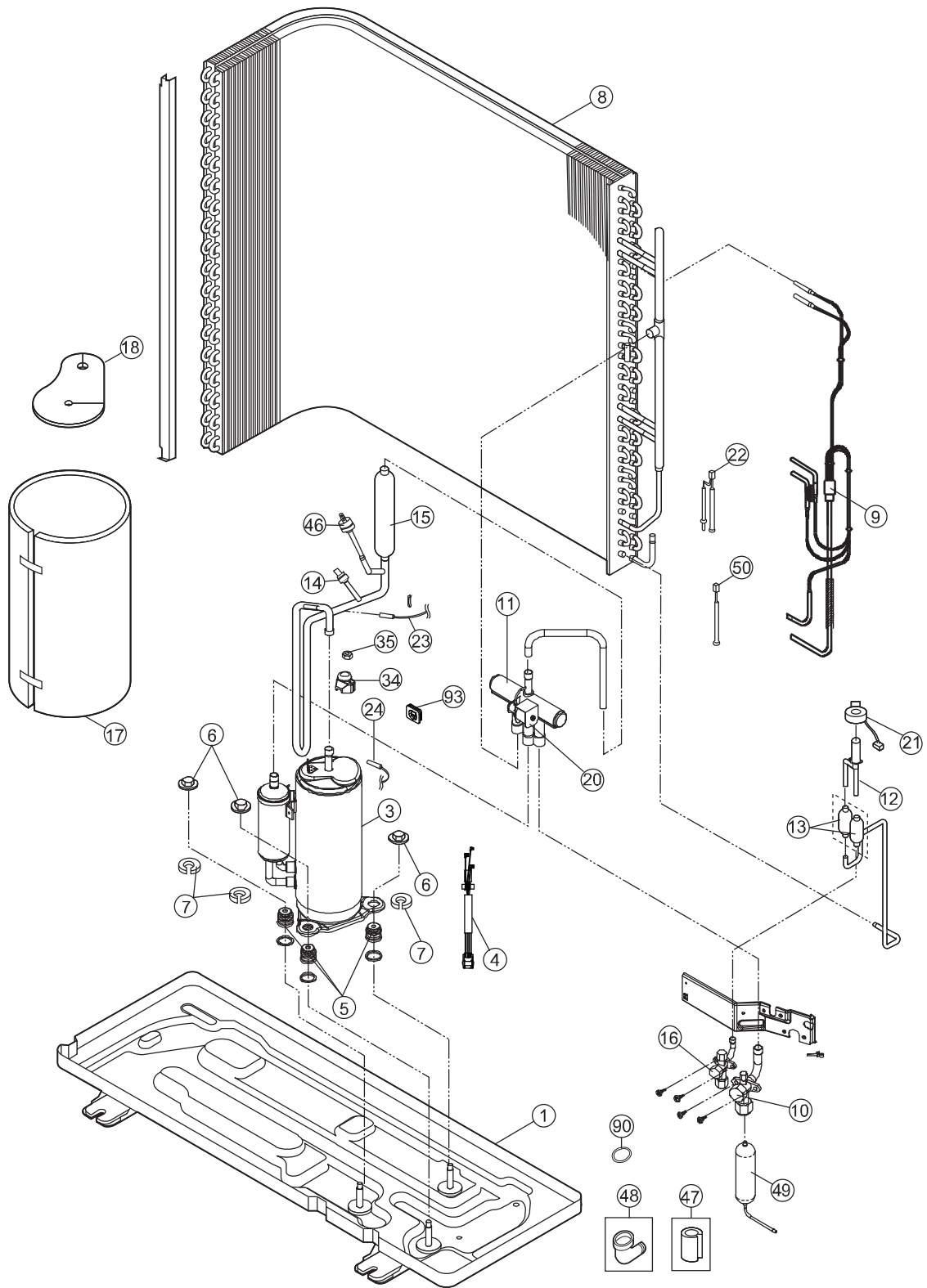

Note:
 The above exploded view is for the purpose of parts disassembly and replacement.
 The non-numbered parts are not kept as standard service parts.

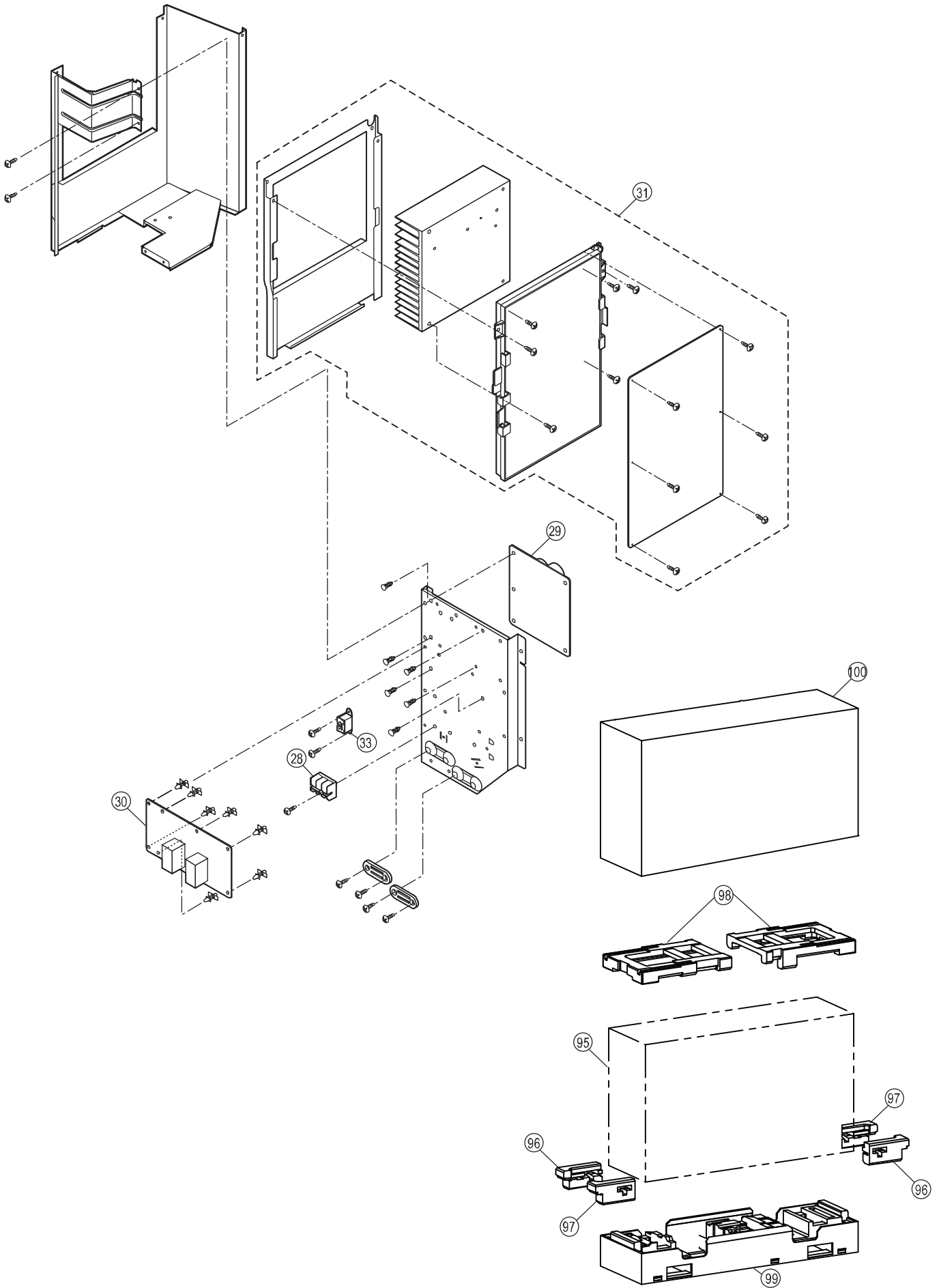

Note:
 The above exploded view is for the purpose of parts disassembly and replacement.
 The non-numbered parts are not kept as standard service parts.

<Model: WH-MDC05J3E5>

SAFETY	REF. NO.	DESCRIPTION & NAME	QTY.	WH-MDC05J3E5	REMARK
	1	BASE PAN ASS'Y (1)	1	CWD52K1282	
	2	BASE PAN ASS'Y (2)	1	ACXD52K03580	
	3	COMPRESSOR	1	9KD240XBD21	O
	4	LEADWIRE COMPRESSOR	1	CWA68C1810	O
	5	BUSHING - COMPRESSOR MOUNT	3	CWH50055	
	6	NUT-COMPRESSOR MOUNT	3	CWH561049	
	7	GASKET FOR TERMINAL COVER	3	CWB811017	
	8	CONDENSER CO.	1	ACXB32C09150	
	9	TUBE ASSY (CAP.TUBE)	1	CWT07K1547	
	10	3-WAYS VALVE (GAS)	1	CWB011700	
	11	4-WAYS VALVE	1	CWB001026J	
	12	EXPANSION VALVE	1	CWB051029	
	13	STRAINER	2	CWB111024	
	14	HIGH PRESSURE SENSOR CN-HPS	1	CWA501463	
	15	DISCHARGE MUFFLER	1	CWB121013	
	16	3-WAYS VALVE(LIQUID)	1	CWB011698	
	17	SOUND PROOF MATERIAL - COMP. BODY	1	ACXG30-10121	
	18	SOUND PROOF MATERIAL - COMP. TOP	1	CWG302246	
	19	SOUND PROOF BOARD	1	CWH151429	
	20	V-COIL COMPLETE(4 WAY VALVE)	1	CWA43C2169J	O
	21	V-COIL COMPLETE(MAIN EXPANSION VALVE)	1	CWA43C2342	O
	22	SENSOR-COMP.(OUTDOOR AIR,PIPE TEMP)	1	CWA50C2652	O
	23	SENSOR-COMP.(DISCHARGE TEMP)	1	CWA50C2528	O
	24	SENSOR-COMP.(DEFROST TEMP)	1	CWA50C2665	O
	25	SOUND PROOF MATERIAL	1	ACXG30-10190	
	26	CABINET REAR PLATE-COMPLETE	1	ACXE02C01210	
	28	TERMINAL BOARD ASS'Y(1,2,3,4,5)	1	CWA28K1251	O
	29	ELECTRONIC CO.(CAPACITOR)	1	CWA746184	O
	30	ELECTRONIC CO.(NOISE FILTER)	1	ACXA73-34930	O
	31	ELECTRONIC CONTROLLER (MAIN) - REFRIGERANT	1	ACXA73C58260R	O
	32	REACTOR	1	G0C193J00021	O
	33	ELECTRO MAGNETIC SWITCH	-	-	O
	34	TERMINAL COVER	1	CWH171039A	
	35	NUT - TERMINAL COVER	1	CWH7080300J	
	36	FAN MOTOR BRACKET	1	ACXD54K02150	
	37	SCREW-FAN MOTOR BRACKET	4	CWH551040J	
	38	FAN MOTOR	1	EHDS80C60AC	O
	39	SCREW-FAN MOTOR MOUNT	4	CWH551323	
	40	PROPELLER FAN ASSY	1	CWH00K1006	
	41	NUT	1	CWH561092	
	42	CABINET FRONT PLATE	1	ACXE06-03400A	
	43	DISCHARGE GRILLE	1	CWE201154	
	44	CABINET SIDE PLATE ASSY	1	CWE04K1019A	
	45	WIRE NET	1	CWD041059	
	46	HIGH PRESSURE SWITCH	1	CWA101013	

SAFETY	REF. NO.	DESCRIPTION & NAME	QTY.	WH-MDC05J3E5	REMARK
	47	ACCESSORY CO.(RUBBER CAP)	1	CWH82C1839	
	48	ACCESSORY CO.(DRAIN ELBOW)	1	CWG87C900	
	49	RECEIVER	1	ACXB14-00670	
⚠	50	SENSOR-COMPLETE	1	CWA50C3379	O
⚠	51	BASE PAN HEATER	1	CWA341071	O
	52	HOT WATER COIL-COMPLETE	1	ACXB90C00960	
	53	FILTER COMPLETE	1	ACXB51C00100	
⚠	54	HEATER ASS'Y	1	ACXA34K00240	O
⚠	55	THERMOSTAT	2	CWA151074	O
	56	TERMINAL COVER	1	CWH171051	
	57	FLOW SENSOR	1	ACXB62-00911	
⚠	58	PUMP	1	ACXB53-00390	O
	59	PRESSURE GAUGE	1	CWB070003	
	60	AIR PURGE VALVE	1	ACXB62-00130	
	61	PRESSURE RELIEF VALVE	1	ACXB62-00740	
	62	CABINET SIDE PLATE	1	ACXE04-11720A	
⚠	63	ELECTRONIC CONTROLLER (MAIN) - WATER	1	ACXA73C58300R	O
	64	CIRCUIT BREAKER	1	CWA181005	O
⚠	65	REACTOR	1	G0C103Z00003	O
⚠	66	TERMINAL BOARD ASS'Y(1,2,3,4,5,6)	1	CWA28K1341	O
⚠	67	TERMINAL BOARD ASS'Y(7,8,9,10,11,12)	2	CWA28K1340	O
⚠	68	TERMINAL BOARD ASS'Y(13,14,15,16,17,18)	3	CWA28K1343	O
⚠	69	TERMINAL BOARD ASS'Y(A,B)	1	CWA28K1238	O
⚠	70	SENSOR-COMPLETE(WATER IN,OUT, REF TEMP)	1	ACXA50C06750	O
⚠	71	SENSOR-COMPLETE(HEX WATER OUTLET)	1	ACXA50C06660	O
⚠	72	REMOTE CONTROL COMPLETE	1	ACXA75C15750	O
	73	RECEIVER	1	CWB141066	
	74	HANDLE	4	CWE161021	
	75	SOUND PROOF MATERIAL	1	ACXG30-10210	
	76	CABINET FRONT PLATE CO.	1	ACXE06C03790	
	77	CABINET FRONT PLATE	1	ACXE06-04500A	
	78	CABINET TOP PLATE CO.	1	ACXE03C01980	
	79	OPERATING INSTRUCTION	1	ACXF55-26660	
	80	OPERATING INSTRUCTION	1	ACXF55-26670	
	81	OPERATING INSTRUCTION	1	ACXF55-26680	
	82	OPERATING INSTRUCTION	1	ACXF55-26690	
	83	OPERATING INSTRUCTION	1	ACXF55-26700	
	84	OPERATING INSTRUCTION	1	ACXF55-26710	
	85	OPERATING INSTRUCTION	1	ACXF55-27620	
	86	INSTALLATION INSTRUCTION	1	ACXF60-38370	
	87	INSTALLATION INSTRUCTION	1	ACXF60-38380	
	88	PANASONIC BADGE	1	CWE373439	
	89	INVERTER BADGE	1	CWE373441	
	90	PACKING-L.TUBE	1	CWB81012	
	91	CONNECTING BAR	1	CWE261213A	
	92	CONNECTING BAR	1	CWE261214A	
	93	GASKET FOR TERMINAL COVER	1	CWB811177	

SAFETY	REF. NO.	DESCRIPTION & NAME	QTY.	WH-MDC05J3E5	REMARK
	94	HOLDER COUPLING	1	ACXH35-01880A	
	95	BAG	1	CWG861483	
	96	SHOCK ABSORBER	2	CWG713660	
	97	SHOCK ABSORBER	2	CWG713661	
	98	SHOCK ABSORBER	2	CWG713662	
	99	BASE BOARD-COMPLETE	1	ACXG62C02080	
	100	C.C.CASE	1	ACXG50-55100	
	101	MODEL LABEL	2	ACXF85-31560	

Note:

- All parts are supplied from PAPAMY, Malaysia (Vendor Code: 00029488).
- "O" marked parts are recommended to be kept in stock.