

21.2.2 WH-UDZ16KE8

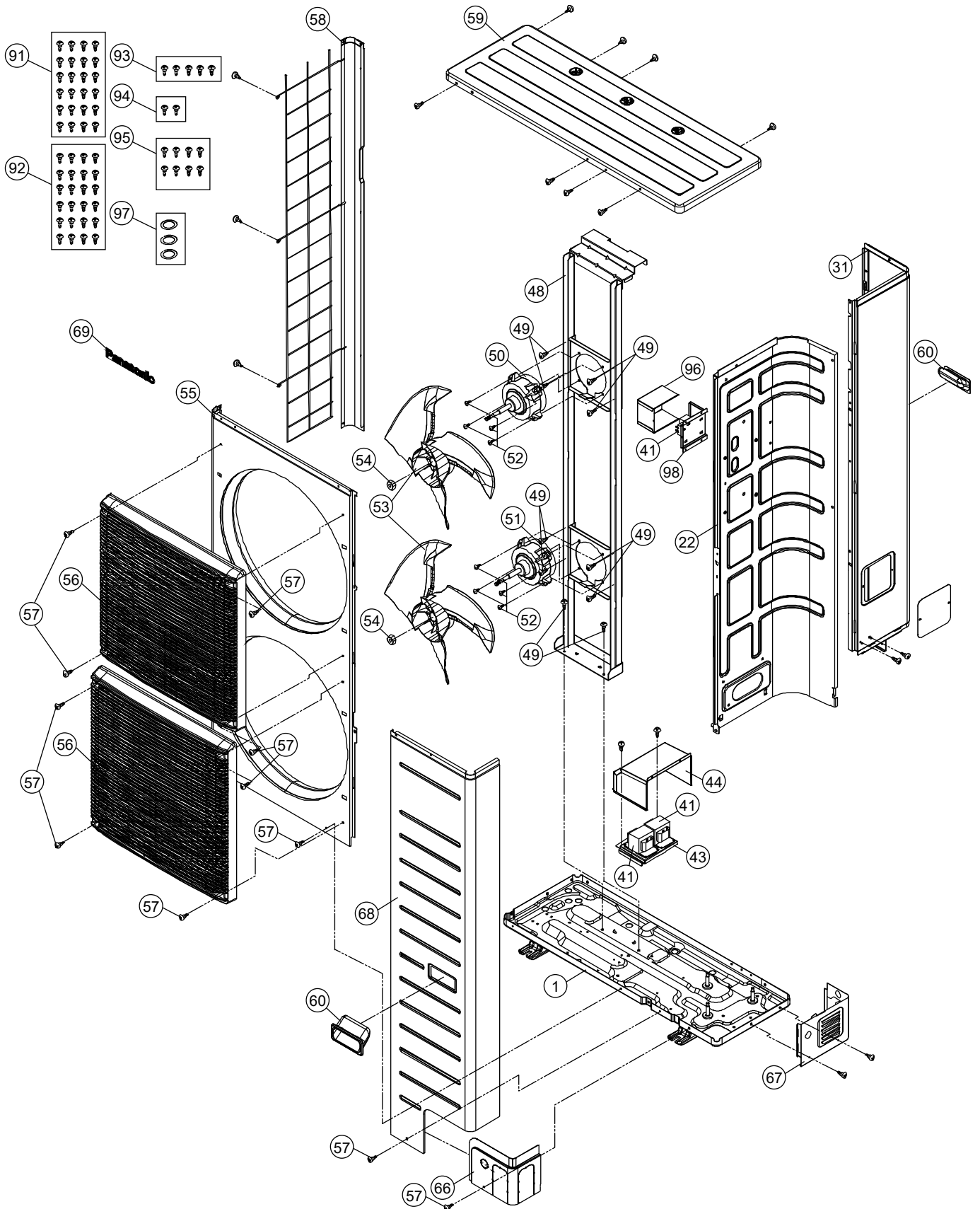

Note:

The above exploded view is for the purpose of parts disassembly and replacement. The non-numbered parts are not kept as standard service parts.

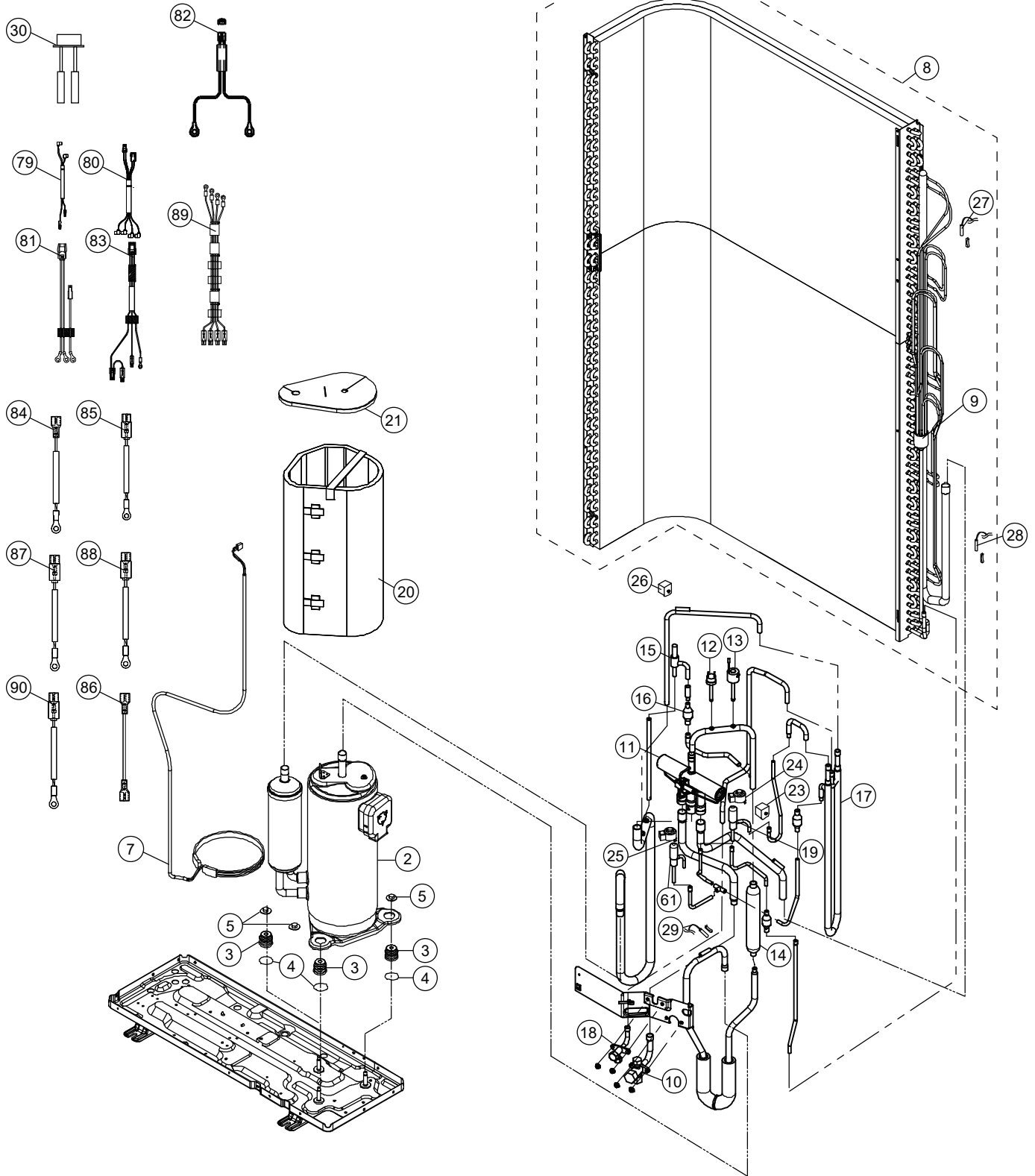

Note:
 The above exploded view is for the purpose of parts disassembly and replacement.
 The non-numbered parts are not kept as standard service parts.

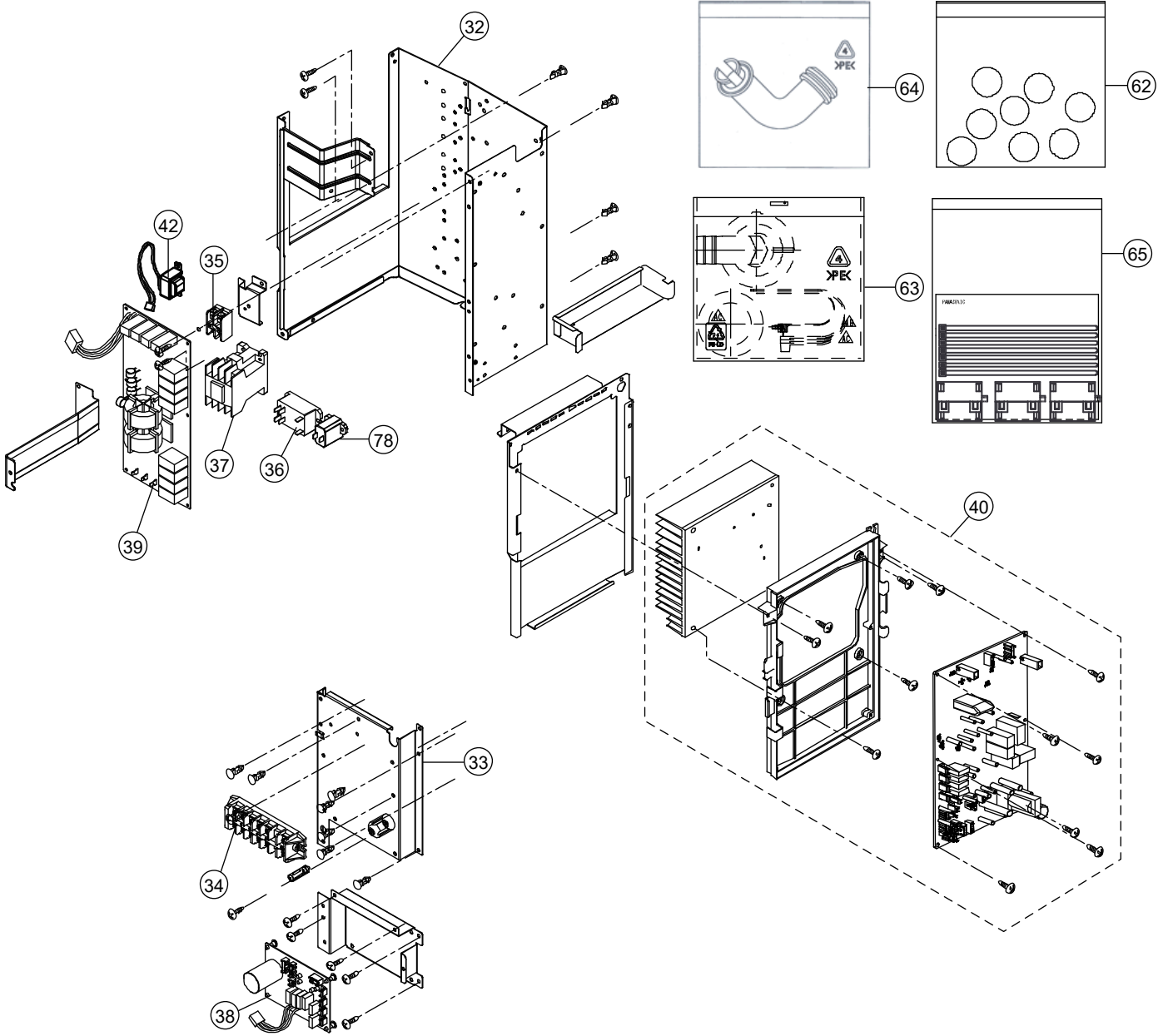





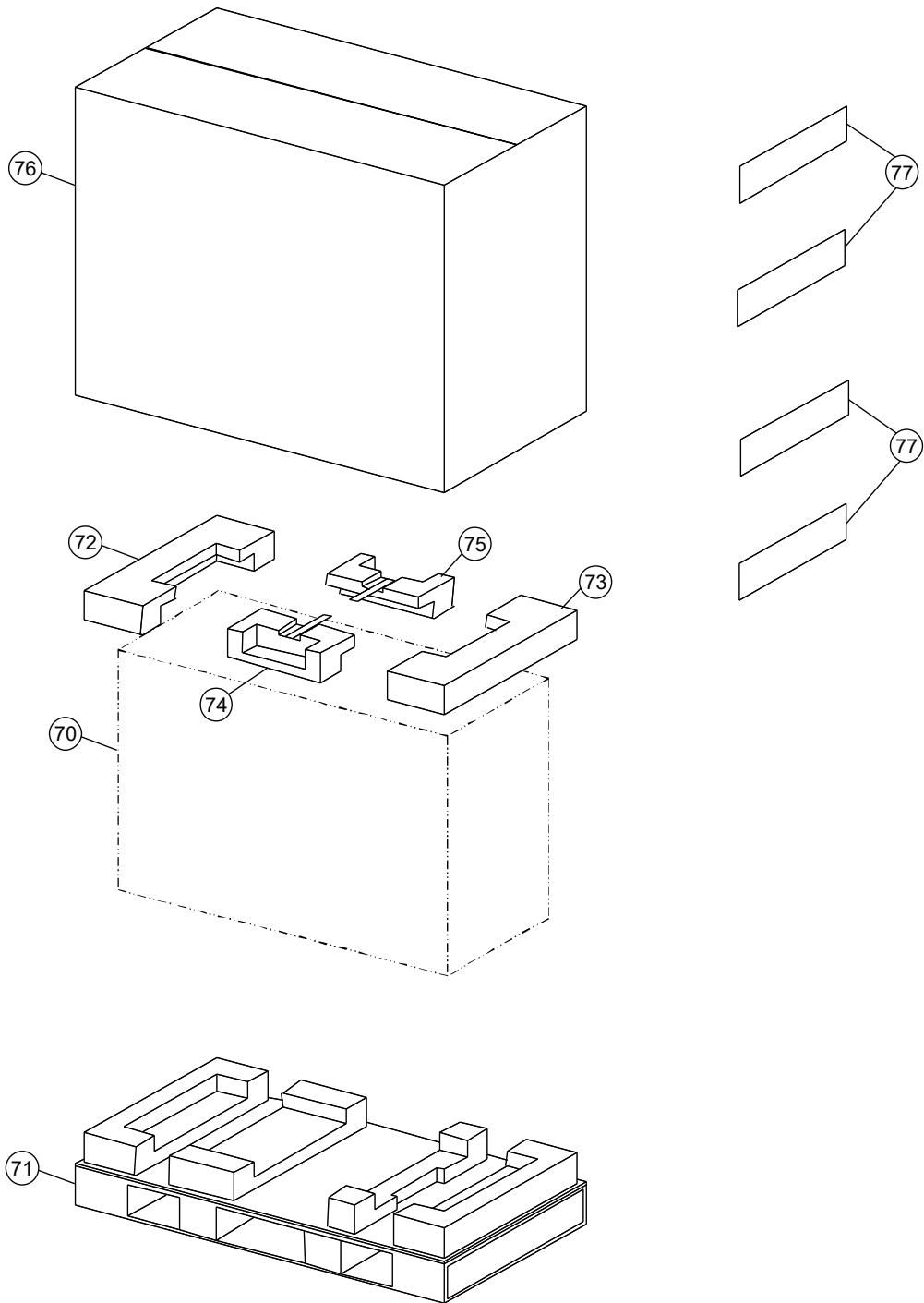











Note:



The above exploded view is for the purpose of parts disassembly and replacement.
 The non-numbered parts are not kept as standard service parts.









Note:

The above exploded view is for the purpose of parts disassembly and replacement. The non-numbered parts are not kept as standard service parts.

SAFETY	REF. NO.	DESCRIPTION & NAME	QTY.	WH-UDZ16KE8	REMARK
	1	BASE PAN ASS'Y	1	ACXD52K00260	
	2	COMPRESSOR	1	9JD650XAA22	O
	3	BUSHING - COMPRESSOR MOUNT	3	CWH50055	
	4	PACKING	3	CWB811017	
	5	NUT - COMPRESSOR MOUNT	3	CWH561049	
	7	HEATER	1	ACXA34-00110	O
	8	CONDENSER	1	ACXB32C28240	O
	9	TUBE ASSY (CAP. TUBE)	1	ACXT07K09172	
	10	3-WAYS VALVE (GAS)	1	ACXB01-06230	O
	11	4-WAYS VALVE	1	ACXB00-01530	O
	12	PRESSURE SWITCH	1	ACXA10-00640	
	13	HIGH PRESSURE SENSOR	1	ACXA50-05990	O
	14	DISCHARGE MUFFLER	1	CWB121014	
	15	2-WAYS VALVE	1	CWB021637	O
	16	STRAINER	1	CWB111032	
	17	TUBE HEAT EXCHANGER	1	CWB361003	
	18	2-WAYS VALVE	1	ACXB02-04010	O
	19	EXPANSION VALVE 1	1	CWB051091	
	20	SOUND PROOF MATERIAL - COMP. BODY	1	ACXG30-11370	
	21	SOUND PROOF MATERIAL - COMP. TOP	1	ACXG30-11380	
	22	SOUND PROOF BOARD	1	CWH151243	
	23	V-COIL COMPLETE (CN-HOT)	1	CWA43C2169J	O
	24	V-COIL COMPLETE (CN-EV)	1	ACXA43C06900	O
	25	V-COIL COMPLETE (CN-EV2)	1	CWA43C2335	O
	26	V-COIL COMPLETE (CN-V1)	1	CWA43C2607	O
	27	SENSOR - COMPLETE (CN-TH1)	1	ACXA50C16850	O
	28	SENSOR - COMPLETE (CN-TH2)	1	ACXA50C19270	O
	29	SENSOR - COMPLETE (CN-DIS)	1	CWA50C2576	O
	30	SENSOR - COMPLETE (CN-TH3)	1	CWA50C3165	O
	31	CABINET REAR PLATE - COMPLETE	1	ACXE02C01950	O
	32	CONTROL BOARD ASS'Y	1	CWH10K1228	
	33	BOX SHAPED PLATE	1	ACXD66-04240	
	34	TERMINAL BOARD ASS'Y	1	CWA28K1214	O
	35	TERMINAL BOARD ASS'Y	1	CWA28K1326	O
	36	MAGNET RELAY - RY1	1	K6C2AGA00002	O
	37	MAGNET RELAY - RY2	1	K6C4E8A00001	O
	38	ELECTRONIC CONTROLLER - SUB	1	ACXA73-36370	O
	39	ELECTRONIC CONTROLLER - NF	1	ACXA73-50060	O
	40	ELECTRONIC CONTROLLER (MAIN)	1	ACXA74C01950R	O
	41	REACTOR 1, 2, 3	3	G0C392J00040	O

SAFETY	REF. NO.	DESCRIPTION & NAME	QTY.	WH-UDZ16KE8	REMARK
	42	REACTOR 4	1	G0C103Z00003	O
	43	U-SHAPED PLATE - COMPLETE	1	ACXD62C00580	
	44	PARTICULAR PLATE - A'SSY	1	CWD90K1023	
	48	FAN MOTOR BRACKET	1	ACXD54K02380	
	49	SCREW - FAN MOTOR BRACKET	10	CWH551040J	
	50	FAN MOTOR (UPPER)	1	L6CBYYL0362	O
	51	FAN MOTOR (LOWER)	1	L6CBYYL0363	O
	52	SCREW - FAN MOTOR MOUNT	8	CWH551323	
	53	PROPELLER FAN ASSY	2	CWH00K1006	
	54	NUT	2	CWH561092	
	55	CABINET FRONT PLATE	1	CWE061098G	
	56	DISCHARGE GRILLE	2	CWE201154G	
	57	SCREW	11	ACXH55-07740	
	58	CABINET SIDE PLATE ASSY	1	CWE04K1023G	
	59	CABINET TOP PLATE - COMPLETE	1	ACXE03C02300	
	60	HANDLE	2	CWE161008G	
	61	EXPANSION VALVE 2	1	CWB051029	
	62	ACCESSORY - COMPLETE	1	ACXH82C03550	
	63	ACCESSORY - COMPLETE	1	ACXH82C26601	
	64	ACCESSORY CO. (DRAIN ELBOW)	1	ACXH82C21740	
	65	ACCESSORY - COMPLETE	1	ACXH82C29040	
	66	L-SHAPED PLATE	1	CWD601074G	
	67	L-SHAPED PLATE	1	CWD601075G	
	68	CABINET FRONT PLATE - COMPLETE	1	ACXE06C04710	
	69	PANASONIC BADGE	1	ACXE37-19200	
	70	BAG	1	ACXG86-05850	
	71	BASE BOARD - COMPLETE	1	ACXG62C02550	
	72	SHOCK ABSORBER	1	ACXG70-13690A	
	73	SHOCK ABSORBER	1	ACXG70-13700A	
	74	SHOCK ABSORBER	1	ACXG70-13710A	
	75	SHOCK ABSORBER	1	ACXG70-13720A	
	76	C.C. CASE	1	ACXG50-58522	
	77	MODEL LABEL	2	ACXF87-23690	
	78	PTC THERMISTORS	1	D4DDG1010001	
	79	LEAD WIRE - COMP - REACTOR 1, 2, 3	1	ACXA60C84520	O
	80	LEAD WIRE - COMP	1	ACXA60C84530	O
	81	LEAD WIRE - COMP	1	ACXA61C00420	O
	82	LEAD WIRE - COMP	1	CWA68C1225	O
	83	LEAD WIRE - COMP - REACTOR 4	1	ACXA61C00410	O
	84	LEAD WIRE - COMP	1	ACXA60C84510	O

SAFETY	REF. NO.	DESCRIPTION & NAME	QTY.	WH-UDZ16KE8	REMARK
	85	LEAD WIRE - COMP	1	ACXA60C84500	O
	86	LEAD WIRE - COMP	1	CWA67C8587	O
	87	LEAD WIRE - COMP	1	CWA67C8591	O
	88	LEAD WIRE - COMP	1	CWA67C8592	O
	89	LEAD WIRE - COMP [TERMINAL BOARD TO NOISE FILTER]	1	ACXA60C98900	O
	90	LEAD WIRE - COMP	1	ACXA60C84620	O
	91	SCREW	24	ACXH55-07140	
	92	SCREW	24	ACXH55-07980	
	93	SCREW	5	CWH55406J	
	94	SCREW	2	CWH55082J	
	95	SCREW	8	CWH551323	
	96	BOX SHAPED PLATE	1	CWD661206	
	97	RUBBER	3	CWG251016	
	98	L-SHAPED PLATE	1	CWD601210	

Note:

- All parts are supplied from PAPAMY, Malaysia (Vendor Code: 00029488).
- "O" marked parts are recommended to be kept in stock.